

IVC1 Series PLC

User Manual

Version V1.0
Revision date December 25, 2011

INVT provides customers with technical support. Users may contact the nearest local sales office or service center.

Copyright © 2011 by INVT Automatic Control Technology Co., Ltd.
All rights reserved. The contents in this document are subject to change without notice.

INVT Automatic Control Technology Co., Ltd.
Address: No.4 Building, Gaofa Scientific Industry Park, Longjing, Nanshan District, Shenzhen China
Homepage: www.invt-control.com
E-mail: support9@invt.com.cn

Safety Precautions

To reduce the chance of accident, please read the safety precautions carefully before operation. The Danger, Warning, and Note symbols in this manual do not represent all the safety points to be observed; they are only supplements to various operation safety points. Therefore, the installation and operation personnel must be strictly trained and master the correct operations and all the safety points before actual operation.

When operating INVT PLC products, the safety rules in the industry, the general safety points and special safety instructions specified in this manual must be strictly observed.

These notices are marked as follows according to the level of danger:



Danger: Death, severe personal injury or substantial property damage may result from improper operation.



Warning: Personal injury or property damage may result from improper operation.



Note: Equipment or property damage may result from improper operation.

Notes for designing

The programming must include safety circuit to ensure the safe application of the Programmable Logic Controller (PLC) system upon power off or PLC fault. Note the following when programming:

- The PLC external circuit must include the emergency braking circuit, protection circuit, interlock circuit of forward/reverse rotation, and the interlock switch of position upper/lower limit to protect the equipment.
- Design an external protection circuit and safety mechanism for the output signals of serious accidents.
- All the outputs may be shutdown when the PLC CPU detects system abnormality; and the fault of PLC circuit may result in uncontrolled PLC output. You need to design a suitable external control circuit to ensure normal operation.
- When the PLC output unit such as the relay or transistor is damaged, the output ON or OFF will be uncontrollable.
- The PLC is designed to be used in the electrical environment of indoor area B and C*. However, to prevent the high lightning voltage from damaging the equipment through the ports of power input, signal input or control output, a SPD should be installed in the power supply system.

*: According to IEC61131-2, section 8.3.1 classification declaration.

Notes for installation

- The installation position should be free from the following: dust or oil smoke, conductive dust, corrosive or flammable gas, high temperature, condensation, and rain. Besides, vibration and impact also affect the PLC normal operation and shorten its lifespan; electric shock, fire or misact also damages the product.
- During drilling or wiring, prevent the metal particles or wire segments from falling into the PLC casing, which may cause fire, fault or misact.
- After the PLC installation, clean the ventilation duct to prevent blocking, which may cause bad ventilation, or even fire, faults or misact.
- Do not online connect, plug or unplug cables, which is apt to cause electric shock or damage the circuit.
- Installation and wire connection must be firm and reliable. Poor connection could cause misact.
- Use shielded twisted pair for the I/O of high frequency signal and analog signal to improve system IMS.

Notes for wiring

- Installation and wiring can be done only after the external power supplies are all disconnected. Otherwise there is a danger of electric shock or equipment damage.
- After the wiring, clean the PLC and put the terminal covers in position before power on to avoid electric shock.

- Input AC power through the L and N terminals as stipulated in this manual. Misconnection of the AC power will ruin the PLC.
- Do not use external power to feed the +24V terminal of the basic module, or the module will be damaged.
- Do not lay the PLC input & output signal cables parallel with power cables or cables with strong interference.
- Do not share a GND between the basic module and a power system.

Notes for operation and maintenance

- Do not touch any ports when PLC is powered on, which could result in electric shock or misact.
- Clean the PLC and fasten the terminals only after the power is off, or there is a risk of electric shock.
- Connect or disconnect the communication signal cables and the cables of extension modules or control unit only after the power is off, or there is a risk of equipment damage or misact.
- Do not disassemble the PLC to avoid damaging the inner electrical components.
- Read through this manual carefully. Only after the safety can be ensured can you do operations such as changing the program, running trial operation, and starting/stopping the PLC.

Notes for the product disposal

Note the following when disposing the PLC:

- The capacities on the PCB may explode when burning.
- The main body of the PLC is of plastic, which could release poisonous gas when burning.
- The PLC shall be disposed as industrial waste, or by following the local environmental protection regulations.

Contents

Chapter 1 Prologue	1
Chapter 2 Product Overview	2
2.1 Product Structure	2
2.2 Naming Rule	2
2.3 Model And Configuration	3
2.3.1 Basic Module	3
2.3.2 Extension Module	3
2.4 Technical Features	4
Chapter 3 Product Specification	6
3.1 Sizes	6
3.2 Environmental Requirements	6
3.3 Reliability	6
3.4 Insulation	7
3.5 Power Supply	8
3.5.1 Basic Module Built-in Power	8
3.5.2 Extension Module Power Provided By Basic Module	9
3.5.3 Power Consumption Of Extension Module	10
Chapter 4 I/O Features	12
4.1 AC Basic Module Terminals	12
4.1.1 IVC1-1006MAR And IVC1-1006MAT	12
4.1.2 IVC1-1410MAR And IVC1-1410MAT	13
4.1.3 IVC1-1614MAR And IVC1-1614MAT	14
4.1.4 IVC1-2416MAR And IVC1-2416MAT	15
4.1.5 IVC1-3624MAR And IVC1-3624MAT	16
4.1.6 IVC1-1614MAR1 And IVC1-1614MAT1	17
4.2 DC Basic Module Terminals	18
4.2.1 IVC1-1006MDR And IVC1-1006MDT	18
4.2.2 IVC1-1410MDR And IVC1-1410MDT	19
4.2.3 IVC1-1614MDR And IVC1-1614MDT	20
4.2.4 IVC1-2416MDR And IVC1-2416MDT	21
4.2.5 IVC1-3624MDR And IVC1-3624MDT	22
4.3 Digital Input	22
4.3.1 Input Specification	22
4.3.2 Input Terminal Internal Equivalent Circuit	23
4.3.3 Wiring Of Source Input And Sink Input	25
4.3.4 Input Connection Example	26
4.3.5 Interrupt Function Of Input	27
4.3.6 High-speed Counting Function	27
4.4 Digital Output	27
4.4.1 Use Of Output	27
4.4.2 Output Specification	28

4.4.3 Output Terminal Internal Equivalent Circuit	29
4.4.4 Output Connection Example	30
4.4.5 Special Function Of Output	31
4.5 Input/Output Status Indicator	31
4.6 Analog Input & Output	31
4.6.1 Usage Of Analog Signal Terminal	31
4.6.2 Analog I/O Specification	32
4.6.3 Analog Terminal Configuration	33
Chapter 5 Communication And Networking	34
5.1 Communication Port	34
5.2 Programming Environment	35
5.2.1 Auto Station Programming Tool	35
5.2.2 Programming Cable	35
Chapter 6 Installation	36
6.1 Safe Precaution	36
6.2 Installation Sizes	36
6.2.1 IVC1-1006MA/DR, IVC1-1006MA/DT	36
6.2.2 IVC1-1410MA/DR, IVC1-1410MA/DT	36
6.2.3 IVC1-1614MA/DR, IVC1-1614MA/DT	37
6.2.4 IVC1-2416MA/DR, IVC1-2416MA/DT, IVC1-1614MAR1 And IVC1-1614MAT1	37
6.2.5 IVC1-3624MA/DR, IVC1-3624MA/DT	37
6.2.6 Extension Module	37
6.3 Mechanical Installation	38
6.3.1 Location	38
6.3.2 Procedures	38
6.4 Wiring	39
6.4.1 Precautions	39
6.4.2 Cable Specification	39
6.4.3 Connecting Power Cables	40
6.4.4 Connecting GND Cables	40
6.4.5 Connecting Input And Output Signal Cables	41
6.4.6 Connecting Extension Bus	41
6.5 Setting Addresses For I/O Channels Of Extension Module	41
Chapter 7 First Poweron And O&M	42
7.1 Pre-poweron Inspection	42
7.2 Poweron Operation	42
7.3 RUN & STOP Status Switchover	42
7.3.1 Status Description And Mode Selection	42
7.3.2 How To Start (STOP→RUN)	43
7.3.3 How To Stop (RUN→STOP)	43
7.4 Routine Maintenance	43
Chapter 8 Troubleshooting	44
8.1 Symptom And Handling Method	44
8.2 Error Code	45

Chapter 9 Instruction List	47
Chapter 10 Special Register	50
10.1 Special Intermediate Relay	50
10.2 Special Data Register	55

Chapter 1 Prologue

Thank you for using INVT programmable logic controller (PLC). Before using the IVC1 series PLC product, please carefully read this manual so as to better understand it, fully use it, and ensure safety.

The content of this manual includes:

Hardware specification, features and usage	Introduction of optional parts
Troubleshooting	Instruction list

For the usage of programming software and programming method, please refer to our *Auto Station Programming Software User Manual*, and *IVC1 Series PLC Programming Manual*. For ordering the above user manuals, contact your distributor.

The target reader of this manual is the technical engineering personnel involved in the study, design, installation and O&M of IVC1 series PLC.

Definitions of technical terms

PLC: Programmable Logic Controller

Basic module: or CPU module. It is a basic unit of PLC, consisting of the CPU, I/O interface and power supply

Extension module: all the modules other than the basic module

I/O extension module: the digital input/output extension module

Special function module: function extension modules other than the I/O extension module, such as the analog input/output, and the bus module

Point number: the sum of channels for the digital input and output

Digital signal: input or output signals that have only two states, namely ON and OFF

Analog signal: electric signal that changes continuously, like the output signal of 4 ~ 20mA voltage transducer

Unipolar signal: generally referring to the continuously changing positive signals

Bipolar signal: the continuously changing signals whose polarity could be either positive or negative

High speed pulse: square wave signals with high frequency

Counter: a number register that counts up or down with each pulse input according to the control signal

Bi-directional counter: a counter with up & down pulse input terminals that control the counter to count up and down respectively

AB phase counter: a counter with two orthogonal phase pulse input terminals. It counts up or down according to the frequencies and phase difference of the two signals

Chapter 2 Product Overview

2.1 Product Structure

The structure of IVC1 series basic module is shown in Figure 2-1.

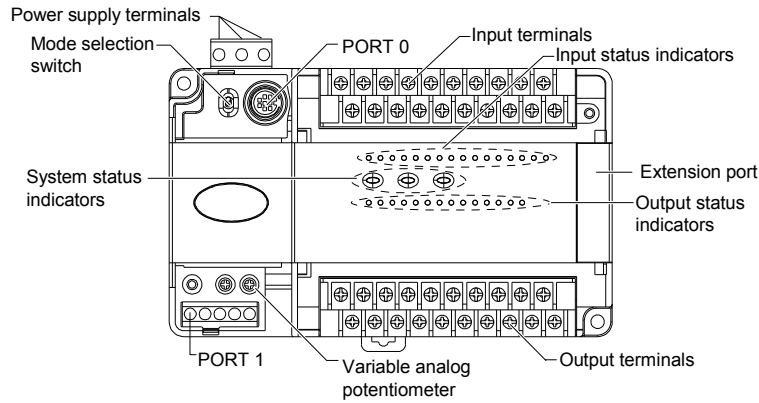

Figure 2-1 Structure of IVC1 series basic module (take IVC1-1614BRA as an example)

PORT0 and PORT1 are communication ports. PORT0 is of RS232 level, with the socket of Mini DIN8. PORT1 provides two levels: RS485 and RS232. The extension port is for connecting extension modules. The mode selection switch offers three options: ON, TM and OFF.

2.2 Naming Rule

The naming rule of PLC is shown in Figure 2-2.

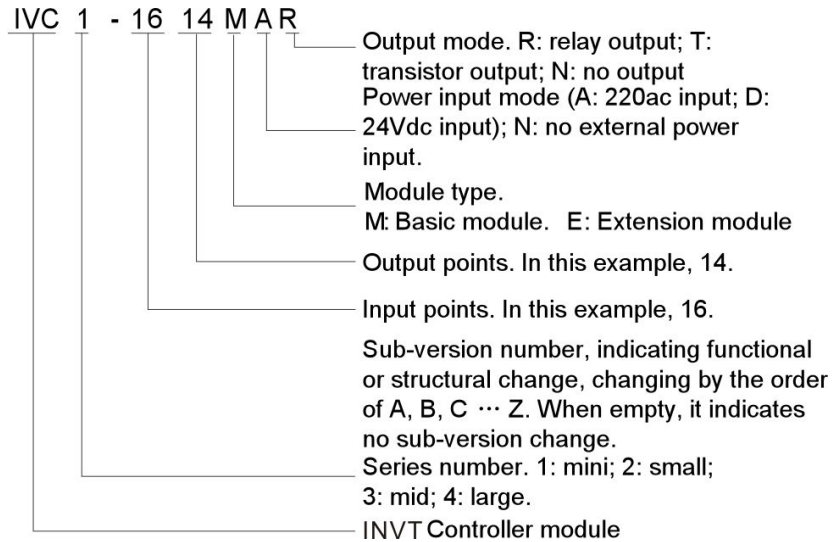

Figure 2-2 Naming rule

2.3 Model And Configuration

2.3.1 Basic Module

IVC1 series PLC and its I/O configuration are listed in Table 2-1 and Table 2-2.

Table 2-1 IVC1 series AC BASIC MODULE and I/O configuration

Model	Power voltage Vac	I/O point number	Digital input voltage	Digital output type	Digital I port / com port	Digital O port/COM port	Analog Input port	Analog output port	Interrupt/pulse input	Pulse output
IVC1-1006MAR	85 ~ 264	10/6	24Vdc	Relay	10/1	6/3	No	No	Yes	No
IVC1-1006MAT	85 ~ 264	10/6	24Vdc	Transistor	10/1	6/3	No	No	Yes	Yes
IVC1-1410MAR	85 ~ 264	14/10	24Vdc	Relay	14/1	10/3	No	No	Yes	No
IVC1-1410MAT	85 ~ 264	14/10	24Vdc	Transistor	14/1	10/3	No	No	Yes	Yes
IVC1-1614MAR	85 ~ 264	16/14	24Vdc	Relay	16/1	14/4	No	No	Yes	No
IVC1-1614MAT	85 ~ 264	16/14	24Vdc	Transistor	16/1	14/4	No	No	Yes	Yes
IVC1-2416MAR	85 ~ 264	24/16	24Vdc	Relay	24/1	16/4	No	No	Yes	No
IVC1-2416MAT	85 ~ 264	24/16	24Vdc	Transistor	24/1	16/4	No	No	Yes	Yes
IVC1-3624MAR	85 ~ 264	36/24	24Vdc	Relay	36/1	24/5	No	No	Yes	No
IVC1-3624MAT	85 ~ 264	36/24	24Vdc	Transistor	36/1	24/5	No	No	Yes	Yes
IVC1-1614MAR1	85 ~ 264	16/14	24Vdc	Relay	16/1	14/4	2	1	Yes	No
IVC1-1614MAT1	85 ~ 264	16/14	24Vdc	Transistor	16/1	14/4	2	1	Yes	Yes

Table 2-2 IVC1 series DC PLC and I/O configuration

Model	Power voltage Vdc	I/O point number	Digital input voltage	Digital output type	Digital I port / com port	Digital O port/COM port	Analog Input port	Analog output port	Interrupt/pulse input	Pulse output
IVC1-1006MDR	19 ~ 30	10/6	24Vdc	Relay	10/1	6/3	No	No	Yes	No
IVC1-1006MDT	19 ~ 30	10/6	24Vdc	Transistor	10/1	6/3	No	No	Yes	Yes
IVC1-1410MDR	19 ~ 30	14/10	24Vdc	Relay	14/1	10/3	No	No	Yes	No
IVC1-1410MDT	19 ~ 30	14/10	24Vdc	Transistor	14/1	10/3	No	No	Yes	Yes
IVC1-1614MDR	19 ~ 30	16/14	24Vdc	Relay	16/1	14/4	No	No	Yes	No
IVC1-1614MDT	19 ~ 30	16/14	24Vdc	Transistor	16/1	14/4	No	No	Yes	Yes
IVC1-2416MDR	19 ~ 30	24/16	24Vdc	Relay	24/1	16/4	No	No	Yes	No
IVC1-2416MDT	19 ~ 30	24/16	24Vdc	Transistor	24/1	16/4	No	No	Yes	Yes
IVC1-3624MDR	19 ~ 30	36/24	24Vdc	Relay	36/1	24/5	No	No	Yes	No
IVC1-3624MDT	19 ~ 30	36/24	24Vdc	Transistor	36/1	24/5	No	No	Yes	Yes

2.3.2 Extension Module

By now the extension modules that IVC1 series PLC provides are shown in Table 2-3. Note that each IVC1 series basic module can be connected with up to four extension modules.

Table 2-3 Extension modules for IVC1 series

Extension module type	Model	Description
I/O extension module	IVC1-0808ENR	8 digital inputs and 8 relay outputs
	IVC1-0808ENT	8 digital inputs and 8 transistor outputs
	IVC1-0800ENN	8 digital inputs and no output
Special module	IVC1-4AD	4 digital inputs
	IVC1-4DA	4 analog outputs
	IVC1-4TC	4 thermocouple temperature inputs
	IVC1-5AM	4 analog inputs, 1 analog output
	IVC1-4PT	4 thermoresistor temperature inputs

I/O extension modules and their configuration are listed in Table 2-4.

Table 2-4 I/O extension modules and configuration

Model	Power voltage Vac	I/O point number	Output type	Built-in power supply
-------	-------------------	------------------	-------------	-----------------------

IVC1-0808ENR	/	08/08	Relay	None
IVC1-0808ENT	/	08/08	Transistor	None
IVC1-0800ENN	/	08/00	/	None

2.4 Technical Features

The basic technical features of IVC1 series PLC are listed in Table 2-5.

Table 2-5 Basic technical features of IVC1 series PLC

Item		Features		
I/O configuration	Max. I/O point number	128		
	Extension module number	4 (the sum of I/O extension module and special function module ≤4)		
Program memory	User program capacity	12k words		
	Data block size	4000 D elements		
Instruction speed	Basic instruction	0.3 μs/ instruction		
	Application instruction	Several μs ~ Several hundred μs/instruction		
Element	I/O relay	128 I / 128 O (Input X0 ~ X177, output Y0 ~ Y177)		
	Auxiliary relay	2048 points (M0 ~ M2047)		
	Local auxiliary relay	64 points (LM0 ~ LM63)		
	Special auxiliary relay	256 points (SM0 ~ SM255)		
	Status relay	1024 points (S0 ~ S1023)		
	Timer	256 points (T0 ~ T255) T0 ~ T209: 100ms; T210 ~ T251: 10ms; T252 ~ T255: 1ms		
	Counter	256 points (C0 ~ C255)	16 bit common up counter: (C0 ~ C199) 32 bit common down counter: (C200 ~ C235) 32 bit high-speed counter: (C236 ~ C255)	
	Data register	8000 points (D0 ~ D7999)		
	Local data register	64 points (V0 ~ V63)		
	Indexed addressing register	16 points (Z0 ~ Z15)		
Special data register	256 points (SD0 ~ SD255)			
Interrupt source	External interrupt input	16 (the interrupt is triggered by the rising & falling edges of ports X0~X7, which can be set by users)		
	High-speed counter interrupt	6		
	Inner timing interrupt	3		
	Communication interrupt	8		
	High-speed output complete interrupt	2		
Power failure interrupt	1			
Communication	Communication port	2 asynchronous serial communication ports PORT0: RS232 PORT1: RS232 or RS485		
	Communication protocol	Programming protocol, MODBUS protocol, free-port protocol, N:N NETWORK (INVT protocol), capable of networking as 1: N or N: N		

Item		Features	
Special function	High speed counter	X0, X1	Single input: 50kHz
		X2 ~ X5	Single input: 10kHz
		X0 ~ X5 simultaneously input: total frequency 60kHz	
	Pulse output	Y0, Y1	100kHz two independent outputs (applicable to only transistor output)
	Input filtering	X0 ~ X7 provide digital filtering, other ports use hardware filtering	
	Variable analog potentiometer *	2	
	Subprogram call	At most 64 subprograms and 6-level subprogram nesting can be used. Support local variables and variable-alias, and every subprogram provides 16 parameters to be called at most	
	User program protection	Uploading password	Three password authorities. Combination of characters and numbers, each not longer than 8 characters. Case sensitive
		Downloading password	
		Monitor password	
		Other protection measures	Protection functions include formatting ban, uploading ban, and subprogram password protection
Programming mode**	Auto Station programming tool***	To be installed in computers	
	PDA handset	Capable of programming and downloading	
Real time clock	Built in, capable of running 100h after a power failure (precondition: the basic module has worked for at least 2 minutes before the power failure)		
<p>*: The analog potentiometer provides users an method for setting inner element, which is within 0~255 and read by user program. To adjust the setting, you can use a small Philips screwdriver to rotate the potentiometer clockwise to raise the setting. The maximum rotation angle is 270°</p> <p>** : Provide register forced function, convenient for debugging and analyzing the user program, improving debugging efficiency. Supportive of forcing 128 bit-registers and 16 word-registers at the same time</p> <p>***: supportive of online user program modification</p>			

Chapter 3 Product Specification

3.1 Sizes

The IVC1 series PLC modules have the same height and width, with lengths related to the I/O terminal number. The sizes of the basic modules and extension modules are listed in Table 3-1.

Table 3-1 Module sizes

Model	Length	Width	Height	Weight
IVC1-1006MAR, IVC1-1006MAT, IVC1-1006MDR, IVC1-1006MDT	135mm	90mm	71.2mm	440g
IVC1-1410MAR, IVC1-1410MAT, IVC1-1410MDR, IVC1-1410MDT	135mm	90mm	71.2mm	470g
IVC1-1614MAR, IVC1-1614MAT, IVC1-1614MDR, IVC1-1614MDT	150mm	90mm	71.2mm	520g
IVC1-2416MAR, IVC1-2416MAT, IVC1-1614MAR1, IVC1-1614MAT1, IVC1-2416MDR, IVC1-2416MDT	182mm	90mm	71.2mm	590g
IVC1-3624MAR, IVC1-3624MAT, IVC1-3624MDR, IVC1-3624MDT	224.5mm	90mm	71.2mm	650g
IVC1-0808ENR, IVC1-0808ENT, IVC1-0800ENN	61mm	90mm	71.2mm	240g
IVC1-4AD, IVC1-4DA, IVC1-5AM, IVC1-4TC, IVC1-4PT IVC1-2AD, IVC1-2DA, IVC1-2TC, IVC1-2PT	61mm	90mm	71.2mm	240g

3.2 Environmental Requirements

The environmental requirements are listed in Table 3-2.

Table 3-2 Work, storage and transportation environmental requirements

Environmental parameter				Work	Transportation	Storage	
Type	Parameter	Unit					
Air condition	Temperature	Low	°C	-5	-40	-40	
		High	°C	55	70	70	
	Humidity	Relative humidity		95 (30 ± 2°C)	95 (40 ± 2°C)	/	
		Pressure	Low	kPa	80	80	80
High	kPa		106	106	106		
Mechanical stress	Sine vibration	Displacement	mm	3.5 (5 ~ 9Hz)	/	/	
		Acceleration	m/s ²	10 (9 ~ 150Hz)	/	/	
	Random vibration	Acceleration spectral density		/	5 ~ 20Hz: 1.92dB 20 ~ 200Hz: -3dB	/	
		Frequency range		Hz	/	5 ~ 200	/
		Direction		/	/	X/Y/Z	/
	Shock	Type		/	/	Half-sine	/
		Acceleration		m/s ²	/	180	/
	Drop	Height		m	/	1	/

3.3 Reliability

The reliability specification of IVC1 series PLC is shown in Table 3-3.

Table 3-3 Reliability specification

Output type	Time	Condition
Relay output	200,000 hours	Fixed to the floor; mechanical stress: { 0; with controlled temperature & humidity
	100,000 hours	Fixed to the floor; mechanical stress: { 0; with uncontrolled temperature & humidity
Transistor output	300,000 hours	Fixed to the floor; mechanical stress: { 0; with controlled temperature & humidity
	150,000 hours	Fixed to the floor; mechanical stress: { 0; with uncontrolled temperature & humidity

As for the relay output PLC, the life span of relay contacts is related to the load, as shown in Table 3-4.

Table 3-4 Output relay contacts life span

Load	Frequency of action	Contact life span
220Vac, 15VA, inductive	1s ON, 1s OFF	3.2 million times
220Vac, 30VA, inductive	1s ON, 1s OFF	1.2 million times
220Vac, 60VA, inductive	1s ON, 1s OFF	0.3 million times

3.4 Insulation

The insulation specification is listed in Table 3-5, Table 3-6 and Table 3-7.

Table 3-5 Insulation specification of AC basic module power input terminals

Type	Name	Rating	Test conditions
Insulation resistance	AC input to casing (\oplus terminal)	$\geq 5 \times 10^6 \Omega$	Ambient temperature $25 \pm 5^\circ\text{C}$; Relative humidity: 90% (non-condensing) Test voltage: 500Vdc
	AC input to user input terminal, and to output terminal	$\geq 5 \times 10^6 \Omega$	
	AC input to extension bus	$\geq 5 \times 10^6 \Omega$	
	User output (relay) to extension bus	$\geq 5 \times 10^6 \Omega$	
	User input to user output (relay)	$\geq 5 \times 10^6 \Omega$	
	Between user output terminal groups (relay)	$\geq 5 \times 10^6 \Omega$	
Insulation strength	AC input to casing (\oplus terminal)	Capable of standing one minute of 2500Vac (50Hz) or RMS current with no breakdown or flashover. Leakage current $\leq 5\text{mA}$	
	AC input to user input and output terminals		
	AC input to extension bus		

Table 3-6 Insulation specification of DC basic module power input terminals

Type	Name	Rating	Test conditions	
Insulation resistance	24Vdc input to output terminal (transistor output)	$\geq 5 \times 10^6 \Omega$	Ambient temperature $25 \pm 5^\circ\text{C}$; Relative humidity: 90% (non-condensing) Test voltage: 500Vdc	
	24Vdc input to casing	$\geq 5 \times 10^6 \Omega$		
	24Vdc input to extension bus			
Insulation strength	24Vdc input to output terminal (transistor output)	Capable of standing one minute of 2500Vac (50Hz) or RMS current with no breakdown or flashover. Leakage current $\leq 5\text{mA}$		
	24Vdc input to casing (PG terminal)			Capable of standing one minute of 500Vac (50Hz) or RMS current with no breakdown or flashover. Leakage current $\leq 5\text{mA}$
	24Vdc input to extension bus			

Table 3-7 Insulation specification of user terminals

Type	Name	Rating	Test conditions
Insulation resistance	User output (transistor) to extension bus	$\geq 5 \times 10^6 \Omega$	Ambient temperature $25 \pm 5^\circ\text{C}$; Relative humidity: 90% (non-condensing) Test voltage: 500Vdc
	Between user input and user output (transistor output)		
	Between user output terminal groups (relay output)		
Insulation strength	User output (relay) to extension bus	Capable of standing one minute of 2500Vac (50Hz) or RMS current with no breakdown or flashover. Leakage current $\leq 5\text{mA}$	
	User input to user output (relay output)		
	Between user output terminal groups (transistor output)		

Note

The circuits not included in the above list are designed by following the SELV circuit requirements.

3.5 Power Supply

3.5.1 Basic Module Built-in Power

The specification of the basic module built-in power is shown in Table 3-8 and Table 3-9.

Table 3-8 IVC1 series AC basic module built-in power specification

Item	Unit	Min.	Typical	Max.	Note	
Input voltage range	Vac	85	220	264	Normal start and work range	
Input current	A	/	/	1.5	90Vac input, 100% output	
Output voltage range	5V/GND	V	4.75	5	5.25	Power for logic circuit of PLC basic module, and for passive extension module through extension terminal
	24V/GND	V	21	24	27	Relay output power for basic module, and for passive extension module through extension terminal. It shares GND with 5V/GND
	24V/COM	V	21	24	27	Basic module 24V power for the user. The cable length should not exceed 30m. It can serve as the auxiliary power for other user circuit, sensor or extension module. It is isolated from 5V/GND and 24V/GND
Output rated current	5V/GND	mA	/	900	/	The total power of 5V/GND and 24V/GND outputs should not exceed 10.4W.
	24V/GND	mA	/	300	/	
	24V/COM	mA	/	600	/	The max. output power is the sum of all branches fully loaded, 24.8W

Table 3-9 IVC1 series DC basic module built-in power specification

Item	Unit	Min.	Typical	Max.	Note	
Input voltage range	Vac	19	24	30	Normal start and work range	
Input current	A	/	0.85	/	24Vdc input	
Output voltage range	5V/GND	V	4.75	5	5.25	Power for logic circuit of basic module, and for passive extension module through extension terminal
	24V/GND	V	21	24	27	Power for relay output of basic module, and for passive extension module through extension terminal. It shares GND with 5V/GND
	5V/GND	mA	/	900	/	The total power of 5V/GND and 24V/GND outputs should not exceed 10.4W
	24V/GND	mA	/	300	/	

3.5.2 Extension Module Power Provided By Basic Module

The power capacity consumption of IVC1 series basic module and the power that basic module can provide for extension modules are listed in Table 3-7.

Table 3-10 IVC1 series AC basic module power capacity consumption and power capacity for extension module

Model	Logic circuit power				Auxiliary power output	
	5V/GND		24V/GND		24V/COM	
	Internal consumption Note1	Max. capacity for extension module Note2	Internal consumption Note1	Max. capacity for extension module Note2	Internal consumption	Max. capacity for extension module
IVC1-1006MAR	200mA	700mA	40 mA	260mA	80mA	520 mA
IVC1-1006MAT	300 mA	600 mA	0	300 mA		520 mA
IVC1-1410MAR	230mA	670mA	50mA	250mA	100mA	500mA
IVC1-1410MAT	350mA	550mA	0	300mA		
IVC1-1614MAR	250mA	650mA	70mA	230mA	140mA	460mA
IVC1-1614MAT	400mA	500mA	0	300mA		
IVC1-2416MAR	320mA	580mA	150mA	150mA	180mA	420mA
IVC1-2416MAT	480mA	420mA	0	300mA		
IVC1-3624MAR	350 mA	550 mA	200 mA	100 mA	300mA	300 mA
IVC1-3624MAT	500 mA	400 mA	0	300 mA		300 mA
IVC1-1614MAR1	250mA	650mA	70mA	230mA	140mA	460mA
IVC1-1614MAT1	400mA	500mA	0	300mA		

Table 3-11 IVC1 series AC basic module power capacity consumption and power capacity for extension module

型号	Logic circuit power			
	5V/GND		24V/GND	
	Internal consumption Note1	Max. capacity for extension module Note2	Internal consumption Note1	Max. capacity for extension module Note2
IVC1-1006MDR	200mA	700mA	40 mA	260mA
IVC1-1006MDT	300 mA	600 mA	0	300 mA
IVC1-1410MDR	230mA	670mA	50mA	250mA
IVC1-1410MDT	350mA	550mA	0	300mA
IVC1-1614MDR	250mA	650mA	70mA	230mA
IVC1-1614MDT	400mA	500mA	0	300mA
IVC1-2416MDR	320mA	580mA	150mA	150mA
IVC1-2416MDT	480mA	420mA	0	300mA
IVC1-3624MDR	350 mA	550 mA	200mA	100 mA
IVC1-3624MDT	500 mA	400 mA	0	300 mA

Note 1: "Internal consumption" is the average work current needed by module internal circuit. Users cannot change it directly.

Note 2: The total power of 5V/GND and 24V/GND is limited. The "Max. capacity for extension module" in the table refers to the max. output capacity of 24V/GND (or 5V/GND) when 5V/GND (or 24V/GND) has no external consumption. When the two output at the same time, you must calculate to ensure the power output does not exceed the capacity limit. See 3.5.3 *Power Consumption Of Extension Module* for details.



Danger

The input power voltage outside the rated range could lead to system abnormality, module damage or even injury to life.

The specifications in tables 3-10 & 3-11 are at the ambient temperature of 25°C. If the highest ambient temperature exceeds +50°C, the output must be reduced to ensure the stable operation. The derating is demonstrated in Figure 3-1.

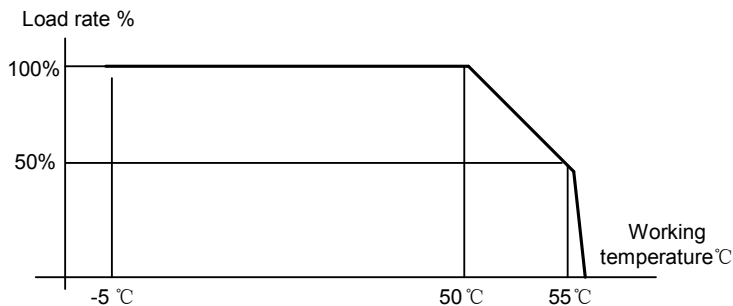

Figure 3-1 Load rate vs. working temperature

3.5.3 Power Consumption Of Extension Module

Max. current consumption

The maximum current consumption of different extension modules is listed in Table 3-12.

Table 3-12 Maximum current consumption of different extension modules

Model	5V/GND	24V/GND	24V/COM
IVC1-0808ENR	70mA	50mA	50mA
IVC1-0808ENT	170mA	0	50mA
IVC1-0800ENN	85mA	0	50mA
IVC1-4AD	60mA	0	50mA
IVC1-4DA	60mA	0	120mA ^{注1}
IVC1-4TC	50mA	0	55mA
IVC1-5AM	50mA	0	90mA*
IVC1-4PT	60mA	0	90mA*

*: Power consumption when the analog output port is loaded. If the current output port (0~20mA) is not used, the current can be decreased to 50mA

Power capacity calculation for extension modules

You must calculate the following two items before connecting extension modules to avoid over-loading the basic module.

1. The sum of current consumption of extension module circuits must be smaller than the corresponding capacity of basic module.
2. When 5V/GND and 24V/GND are all loaded, you must ensure that $5 \times I_{5Voutput} + 24 \times I_{24Voutput} \leq 10.4W$.

Example 1: Basic module: IVC1-1614MAR. Find out whether it is all right to connect an IVC1-0808ENT, an IVC1-4AD, an IVC1-4DA and an IVC1-4TC to it. Ambient temperature: 25°C. The calculation is shown in Table 3-13.

Table 3-13 Calculation 1

Power circuit	Current capacity of basic module	Actual current consumption	Conclusion
5V/GND	650mA	$170 + 60 + 60 + 50 = 340mA$	OK
24V/GND	230mA	$0 + 0 + 0 + 0 = 0mA$	OK
24V/COM	460mA	$50 + 50 + 120 + 55 = 275mA$	OK

In this example, the total consumption of 5V/GND and 24V/GND is $5 \times (0.25 + 0.34) + 24 \times (0.070 + 0) = 4.63W < 10.4W$. The sums of various extension module circuits are all smaller than the basic module corresponding capacity, and the sum of 5V/GND and 24V/GND is also within the capacity range of the basic module. The design is all right.

Example 2: Basic module: IVC1-2416MAT. Extension modules include two IVC1-0808ENTs, an IVC1-4AD and an IVC1-4DA. Use the 20mA output port. Ambient temperature: 25°C. The calculation is shown in Table 3-14.

Table 3-14 Calculation 2

Power circuit	Current capacity of basic module	Actual current consumption	Conclusion
5V/GND	420mA	$170 \times 2 + 60 + 60 = 460\text{mA}$	NO
24V/GND	300mA	$0 \times 2 + 0 + 0 = 0\text{mA}$	OK
24V/COM	420mA	$50 \times 2 + 50 + 120 = 270\text{mA}$	OK

In this example, the 5V/GND of the extension module sums up to 460mA, which is bigger than the corresponding capacity of basic module: 420mA. This design is not passable.

The PLC programming software Auto Station provides a power capacity calculating tool. You can designate a configuration and Auto Station will calculate the power capacity for you.

Chapter 4 I/O Features

4.1 AC Basic Module Terminals

4.1.1 IVC1-1006MAR And IVC1-1006MAT

The terminals of IVC1-1006MAR and IVC1-1006MAT are shown in Figure 4-1, and defined in Table 4-1.

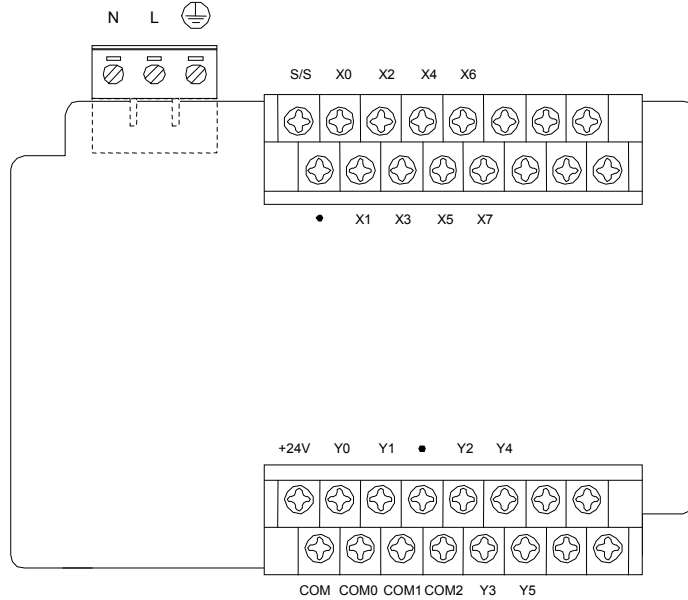

Figure 4-1 Terminals of IVC1-1006MAR and IVC1-1006MAT

Table 4-1 IVC1-1006MAR and IVC1-1006MAT terminal definition

Pin	Function description	
L/N	220Vac input terminal, live and neutral respectively	
⊕	Grounding	
+24V	Auxiliary DC power for external equipment, used together with COM	
COM	Negative pole of the 24V auxiliary power for external equipment	
S/S	Input mode selection: sink mode when connected with +24V, and source mode when connected with COM	
●	Null, for isolation. Leave it suspended	
X0 ~ X11	Digital input terminals. Input signals are generated when used together with COM	
Y0, COM0	Digital output terminals, group 0	The COMx of different output groups are isolated from each other
Y1, COM1	Digital output terminals, group 1	
Y2 ~ Y5, COM2	Digital output terminals, group 2	

4.1.2 IVC1-1410MAR And IVC1-1410MAT

The terminals of IVC1-1410MAR and IVC1-1410MAT are shown in Figure 4-2, and defined in Table 4-2.

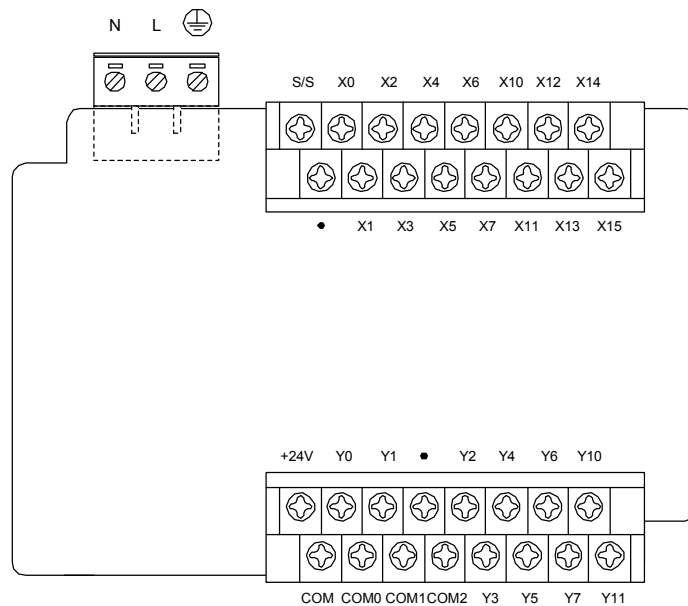

Figure 4-2 Terminals of IVC1-1410MAR and IVC1-1410MAT

Table 4-2 IVC1-1410MAR and IVC1-1410MAT terminal definition

Pin	Function description	
L/N	220Vac input terminal, live and neutral respectively	
⊕	Grounding	
+24V	Auxiliary DC power for external equipment, used together with COM	
COM	Negative pole of the 24V auxiliary power for external equipment	
S/S	Input mode selection: sink mode when connected with +24V, and source mode when connected with COM	
●	Null, for isolation. Leave it suspended	
X0 ~ X15	Digital input terminals. Input signals are generated when used together with COM	
Y0, COM0	Digital output terminals, group 0	The COMx of different output groups are isolated from each other
Y1, COM1	Digital output terminals, group 1	
Y2 ~ Y11, COM2	Digital output terminals, group 2	

4.1.3 IVC1-1614MAR And IVC1-1614MAT

The terminals of IVC1-1614MAR and IVC1-1614MAT are shown in Figure 4-3, and defined in Table 4-3.

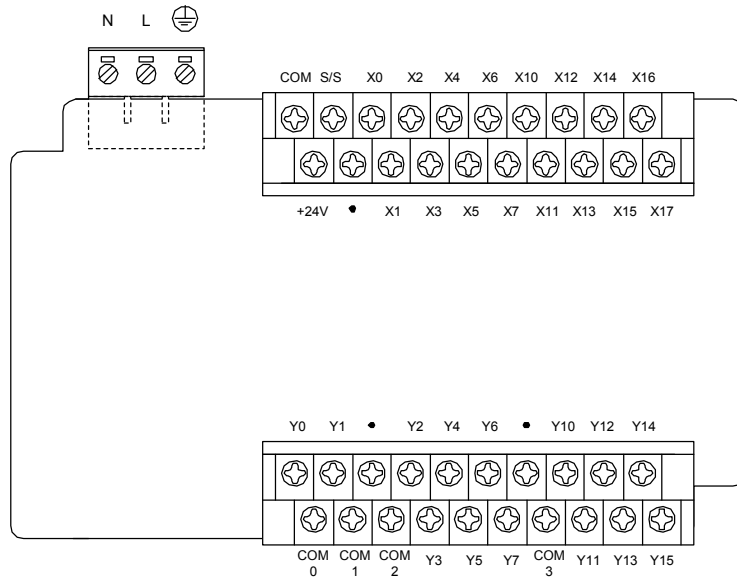

Figure 4-3 Terminals of IVC1-1614MAR and IVC1-1614MAT

Table 4-3 IVC1-1614MAR and IVC1-1614MAT terminal definition

Pin	Function description	
L/N	220Vac input terminal, live and neutral respectively	
⊕	Grounding terminal PG	
+24V	Auxiliary DC power for external equipment, used together with COM	
COM	Negative pole of the 24V auxiliary power for external equipment	
S/S	Input mode selection: sink mode when connected with +24V, and source mode when connected with COM	
●	Null, for isolation. Leave it suspended	
X0 ~ X17	Digital input terminals. Input signals are generated when used together with COM	
Y0, COM0	Digital output terminals, group 0	The COMx of different output groups are isolated from each other
Y1, COM1	Digital output terminals, group 1	
Y2 ~ Y7, COM2	Digital output terminals, group 2	
Y10 ~ Y15, COM3	Digital output terminals, group 3	

4.1.4 IVC1-2416MAR And IVC1-2416MAT

The terminals of IVC1-2416MAR and IVC1-2416MAT are shown in Figure 4-4, and defined in Table 4-4.

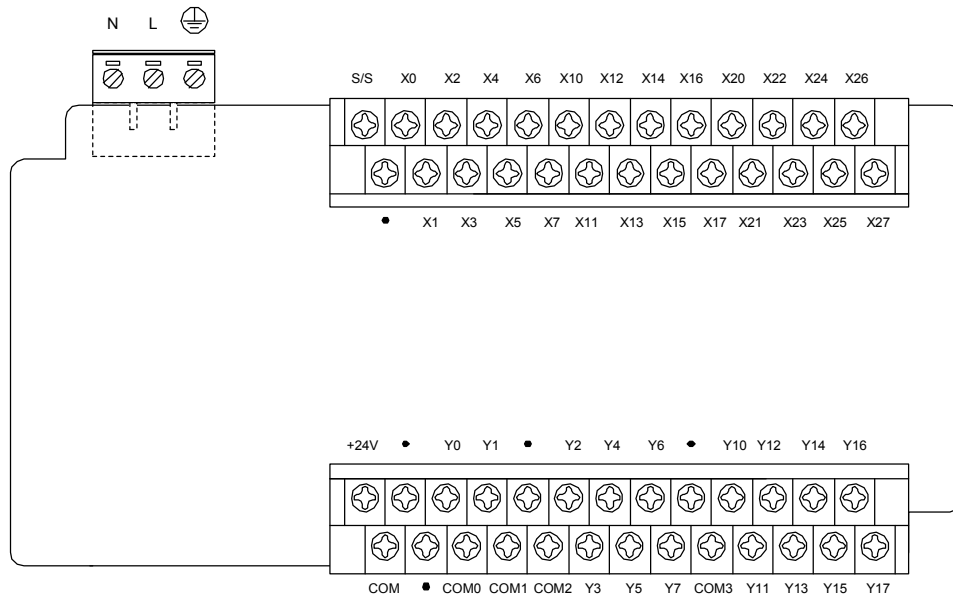

Figure 4-4 Terminals of IVC1-2416MAR and IVC1-2416MAT

Table 4-4 IVC1-2416MAR and IVC1-2416MAT terminal definition

Pin	Function description	
L/N	220Vac input terminal, live and neutral respectively	
⊕	Grounding	
+24V	Auxiliary DC power for external equipment, used together with COM	
COM	Negative pole of the 24V auxiliary power for external equipment	
S/S	Input mode selection: sink mode when connected with +24V, and source mode when connected with COM	
●	Null, for isolation. Leave it suspended	
X0 ~ X27	Digital input terminals. Input signals are generated when used together with COM	
Y0, COM0	Digital output terminals, group 0	The COMx of different output groups are isolated from each other
Y1, COM1	Digital output terminals, group 1	
Y2 ~ Y7, COM2	Digital output terminals, group 2	
Y10 ~ Y17, COM3	Digital output terminals, group 3	

4.1.5 IVC1-3624MAR And IVC1-3624MAT

The terminals of IVC1-3624MAR and IVC1-3624MAT are shown in Figure 4-5, and defined in Table 4-5.

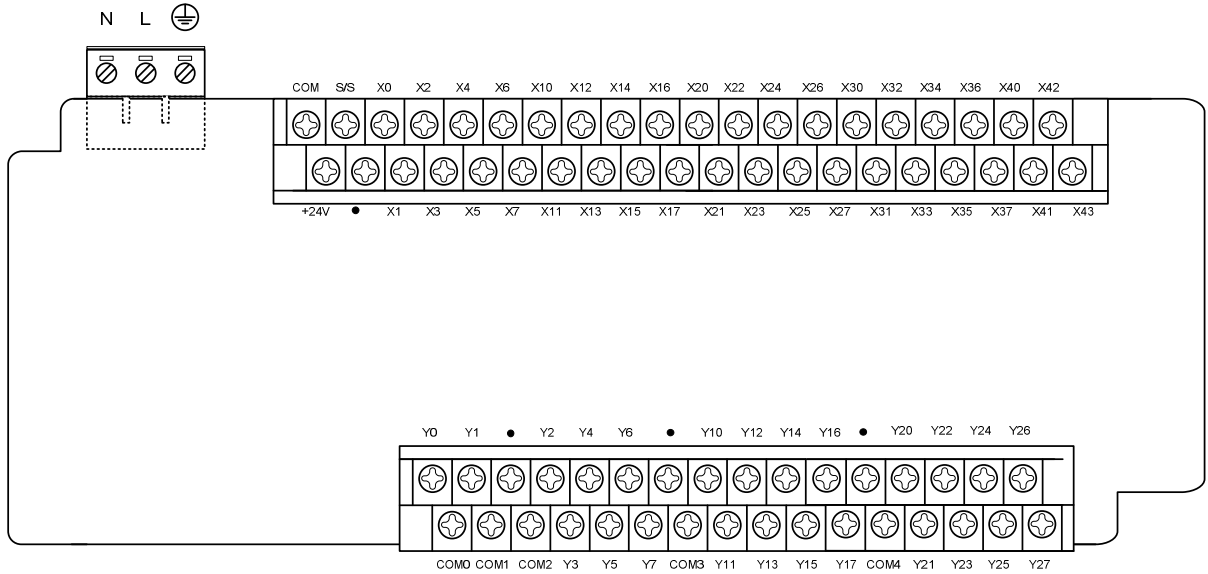

Figure 4-5 Terminals of IVC1-3624MAR and IVC1-3624MAT

Table 4-5 IVC1-3624MAR and IVC1-3624MAT terminal definition

Pin	Function description	
L/N	220Vac input terminal, live and neutral respectively	
⊕	Grounding	
+24V	Auxiliary DC power for external equipment, used together with COM	
COM	Negative pole of the 24V auxiliary power for external equipment	
S/S	Input mode selection: sink mode when connected with +24V, and source mode when connected with COM	
●	Null, for isolation. Leave it suspended	
X0 ~ X43	Digital input terminals. Input signals are generated when used together with COM	
Y0, COM0	Digital output terminals, group 0	The COMx of different output groups are isolated from each other
Y1, COM1	Digital output terminals, group 1	
Y2 ~ Y7, COM2	Digital output terminals, group 2	
Y10 ~ Y17, COM3	Digital output terminals, group 3	
Y20 ~ Y27, COM3	Digital output terminals, group 4	

4.1.6 IVC1-1614MAR1 And IVC1-1614MAT1

The terminals of IVC1-1614MAR1 and IVC1-1614MAT1 are shown in Figure 4-6, and defined in Table 4-6.

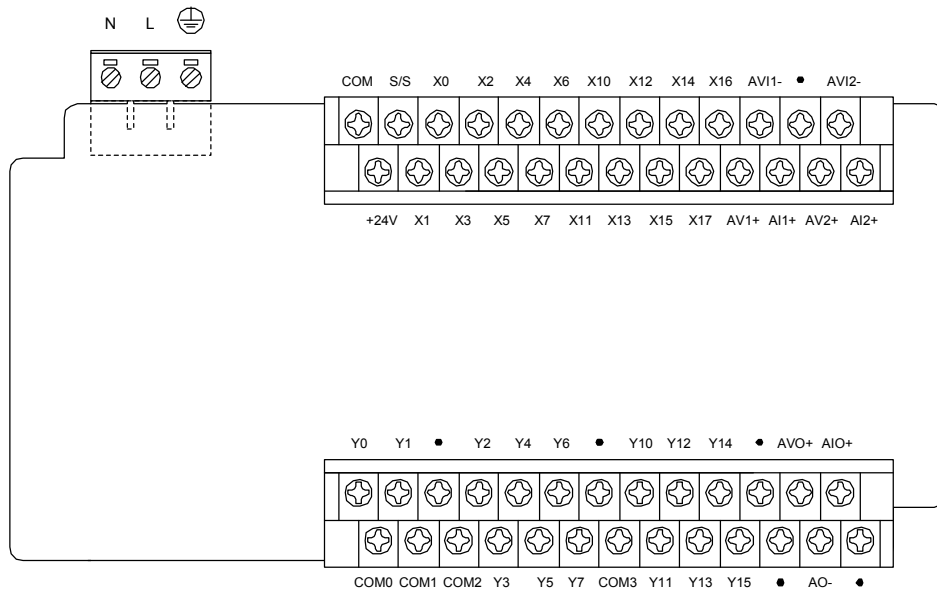

Figure 4-6 Terminals of IVC1-1614MAR1 and IVC1-1614MAT1

Table 4-6 IVC1-1614MAR1 and IVC1-1614MAT1 terminal definition

Pin	Function description	
L/N	220Vac input terminal, live and neutral respectively	
⊕	Grounding terminal PG	
+24V	Auxiliary DC power for external equipment, used together with COM	
COM	Negative pole of the 24V auxiliary power for external equipment	
S/S	Input mode selection: sink mode when connected with +24V, and source mode when connected with COM	
●	Null, for isolation. Leave it suspended	
X0 ~ X17	Digital input terminals. Input signals are generated when used together with COM	
Y0, COM0	Digital output terminals, group 0	The COMx of different output groups are isolated from each other
Y1, COM1	Digital output terminals, group 1	
Y2 ~ Y7, COM2	Digital output terminals, group 2	
Y10 ~ Y15, COM3	Digital output terminals, group 3	
AV1+, AI1+, AV11-	Group 1 analog input terminals. AV1+: positive voltage input. AI1+: positive current input. AV11-: common negative terminal of current input and voltage input	
AV2+, AI2+, AV12-	Group 2 analog input terminals. AV2+: positive voltage input. AI2+: positive current input. AV12-: common negative terminal of current input and voltage input	
AVO+, AIO+, AO-	Analog output terminals. AVO+: positive voltage output. AIO+: positive current output. AO-: common negative terminal of voltage output and current output	

4.2 DC Basic Module Terminals

4.2.1 IVC1-1006MDR And IVC1-1006MDT

The terminals of IVC1-1006MDR and IVC1-1006MDT are shown in Figure 4-7, and defined in Table 4-7.

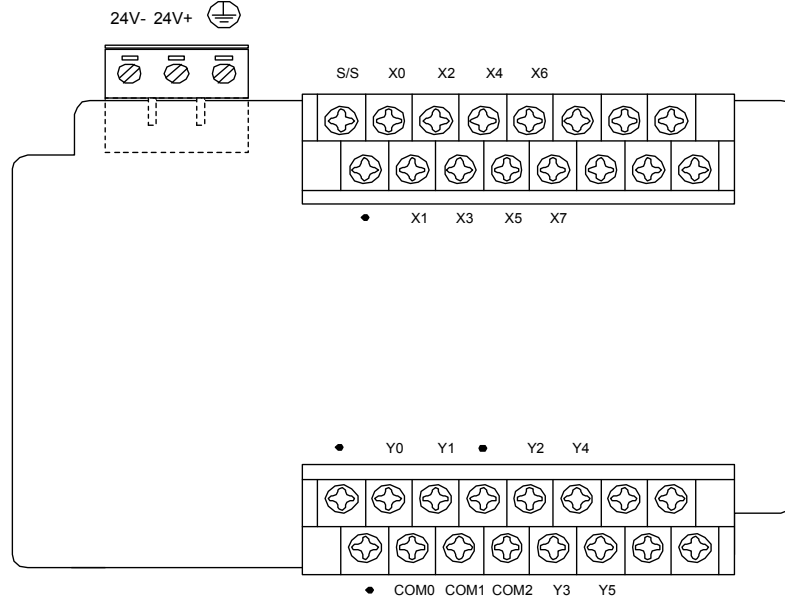

Figure 4-7 Terminals of IVC1-1006MDR and IVC1-1006MDT

Table 4-7 IVC1-1006MDR and IVC1-1006MDT terminal definition

Pin	Function description	
24V+/24V-	The positive and negative input terminals of 24Vdc power	
⊕	PG	
S/S	Input mode selection: sink mode when connected with 24V+, and source mode when connected with 24V-	
●	Null, for isolation. Leave it suspended	
X0 ~ X11	Digital input terminals. Input signals are generated when used together with COM	
Y0, COM0	Control output terminals, group 0	The COMx of different output groups are isolated from each other
Y1, COM1	Control output terminals, group 1	
Y2 ~ Y5, COM2	Control output terminals, group 2	

4.2.2 IVC1-1410MDR And IVC1-1410MDT

The terminals of IVC1-1410MDR and IVC1-1410MDT are shown in Figure 4-8, and defined in Table 4-8.

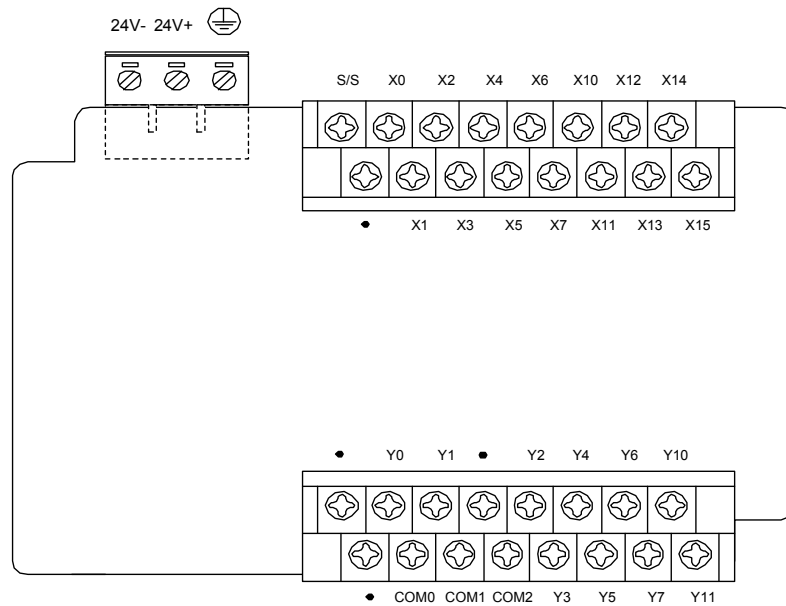

Figure 4-8 Terminals of IVC1-1410MDR and IVC1-1410MDT

Table 4-8 IVC1-1410MDR and IVC1-1410MDT terminal definition

Pin	Function description	
24V+/24V-	The positive and negative input terminals of 24Vdc power	
⊕	PG	
S/S	Input mode selection: sink mode when connected with 24V+, and source mode when connected with 24V-	
●	Null, for isolation. Leave it suspended	
X0 ~ X15	Digital input terminals. Input signals are generated when used together with COM	
Y0, COM0	Control output terminals, group 0	The COMx of different output groups are isolated from each other
Y1, COM1	Control output terminals, group 1	
Y2 ~ Y11, COM2	Control output terminals, group 2	

4.2.3 IVC1-1614MDR And IVC1-1614MDT

The terminals of IVC1-1614MDR and IVC1-1614MDT are shown in Figure 4-9, and defined in Table 4-9.

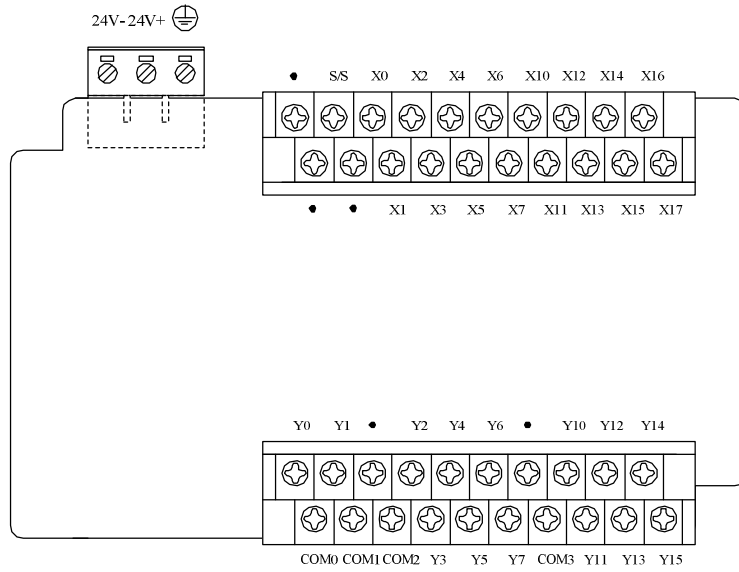

Figure 4-9 Terminals of IVC1-1614MDR and IVC1-1614MDT

Table 4-9 IVC1-1614MDR and IVC1-1614MDT terminal definition

Pin	Function description	
24V+/24V-	The positive and negative input terminals of 24Vdc power	
⊕	PG	
S/S	Input mode selection: sink mode when connected with 24V+, and source mode when connected with 24V-	
●	Null, for isolation. Leave it suspended	
X0 ~ X17	Digital input terminals. Input signals are generated when used together with COM	
Y0, COM0	Control output terminals, group 0	The COMx of different output groups are isolated from each other
Y1, COM1	Control output terminals, group 1	
Y2 ~ Y7, COM2	Control output terminals, group 2	
Y10 ~ Y15, COM3	Control output terminals, group 3	

4.2.4 IVC1-2416MDR And IVC1-2416MDT

The terminals of IVC1-2416MDR and IVC1-2416MDT are shown in Figure 4-10, and defined in Table 4-10.

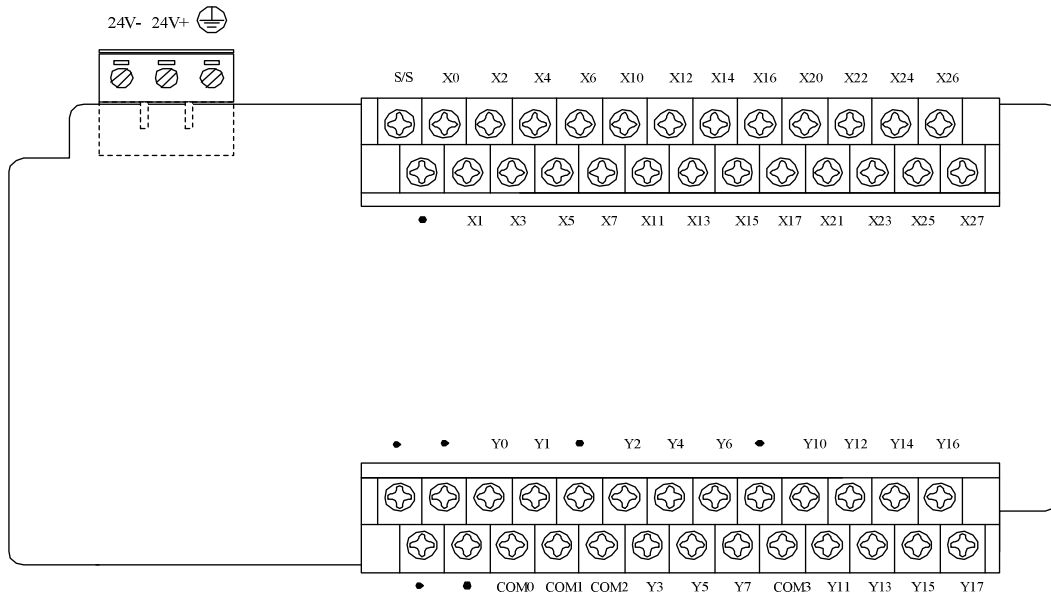

Figure 4-10 Terminals of IVC1-2416MDR and IVC1-2416MDT

Table 4-10 IVC1-2416MDR and IVC1-2416MDT terminal definition

Pin	Function description	
24V+/24V-	The positive and negative input terminals of 24Vdc power	
⊕	PG	
S/S	Input mode selection: sink mode when connected with 24V+, and source mode when connected with 24V-	
●	Null, for isolation. Leave it suspended	
X0 ~ X27	Digital input terminals. Input signals are generated when used together with COM	
Y0, COM0	Control output terminals, group 0	The COMx of different output groups are isolated from each other
Y1, COM1	Control output terminals, group 1	
Y2 ~ Y7, COM2	Control output terminals, group 2	
Y10 ~ Y17, COM3	Control output terminals, group 3	

4.2.5 IVC1-3624MDR And IVC1-3624MDT

The terminals of IVC1-3624MDR and IVC1-3624MDT are shown in Figure 4-11, and defined in Table 4-11.

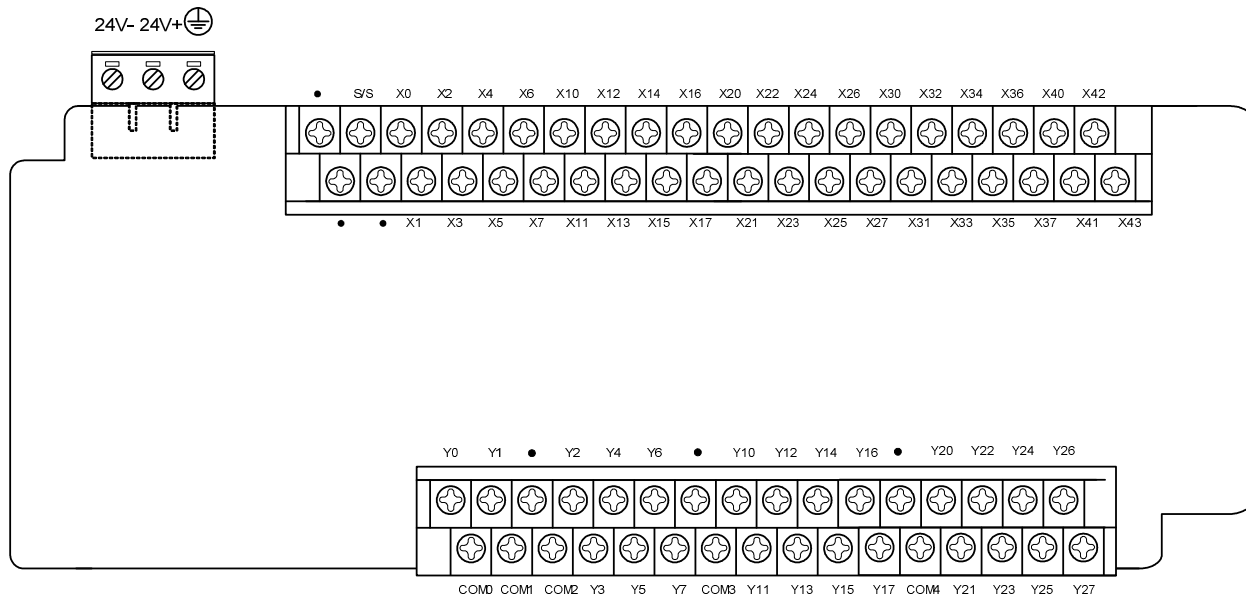

Figure 4-11 Terminals of IVC1-3624MDR and IVC1-3624MDT

Table 4-11 IVC1-3624MDR and IVC1-3624MDT terminal definition

Pin	Function description	
24V+/24V-	The positive and negative input terminals of 24Vdc power	
⊕	PG	
S/S	Input mode selection: sink mode when connected with 24V+, and source mode when connected with 24V-	
●	Null, for isolation. Leave it suspended	
X0 ~ X43	Digital input terminals. Input signals are generated when used together with COM	
Y0, COM0	Control output terminals, group 0	The COMx of different output groups are isolated from each other
Y1, COM1	Control output terminals, group 1	
Y2 ~ Y7, COM2	Control output terminals, group 2	
Y10 ~ Y17, COM3	Control output terminals, group 3	
Y20 ~ Y27, COM3	Control output terminals, group 4	

4.3 Digital Input

4.3.1 Input Specification

The specification of digital Inputs of IVC1 series PLC basic module is shown in Table 4-12.

Table 4-12 Specification of digital input

Item	Specification	
Signal input mode	Sink/source mode, selectable through S/S terminal	
Electric parameter	Test voltage	24Vdc
	Input resistance	X0 ~ X7 terminal: 3.3kΩ. Other terminals: 4.3kΩ
	Input being ON	External circuit resistance smaller than 400Ω
	Input being OFF	External circuit resistance bigger than 24kΩ
Filtering function	Digital filtering	X0 ~ X7 are capable of digital filtering. Filtering time (set through user program): 0ms, 8ms, 16ms, 32ms or 64ms
	Hardware filtering	The I/O terminals except X0 ~ X7 are of hardware filtering. Filtering time: about 10ms
High speed function	X0 ~ X7: capable of high-speed counting, interrupt, and pulse catching X0, X1: max. counting frequency up to 50kHz X2 ~ X5: max. counting frequency up to 10kHz Input frequency sum should be smaller than 60kHz	

Item	Specification
Common terminal	Only one: COM

4.3.2 Input Terminal Internal Equivalent Circuit

The AC basic module has built-in 24Vdc power supply, which can be used by the local input terminals, while the DC basic module requires external 24Vdc power. To connect to the output of active transistor sensor, you need to use the open collector output mode. The PLC S/S terminal is used to select signal input mode between source and sink. You can select the sink input mode by connecting the S/S terminal with the +24V terminal or the positive input of external 24Vdc power, which enables you to connect NPN type sensor. The internal equivalent circuit and external wiring of sink input mode are shown in Figure 4-12 and Figure 4-13. The specific external wiring mode is introduced in 4.2.3 *Wiring Of Source Input And Sink Input*.

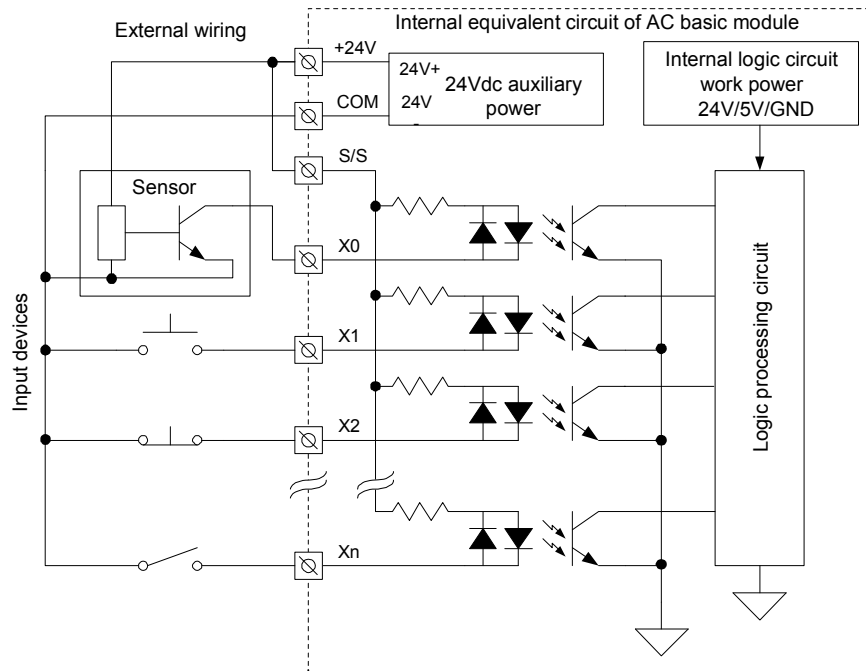

Figure 4-12 Sink input mode internal equivalent circuit of AC basic module

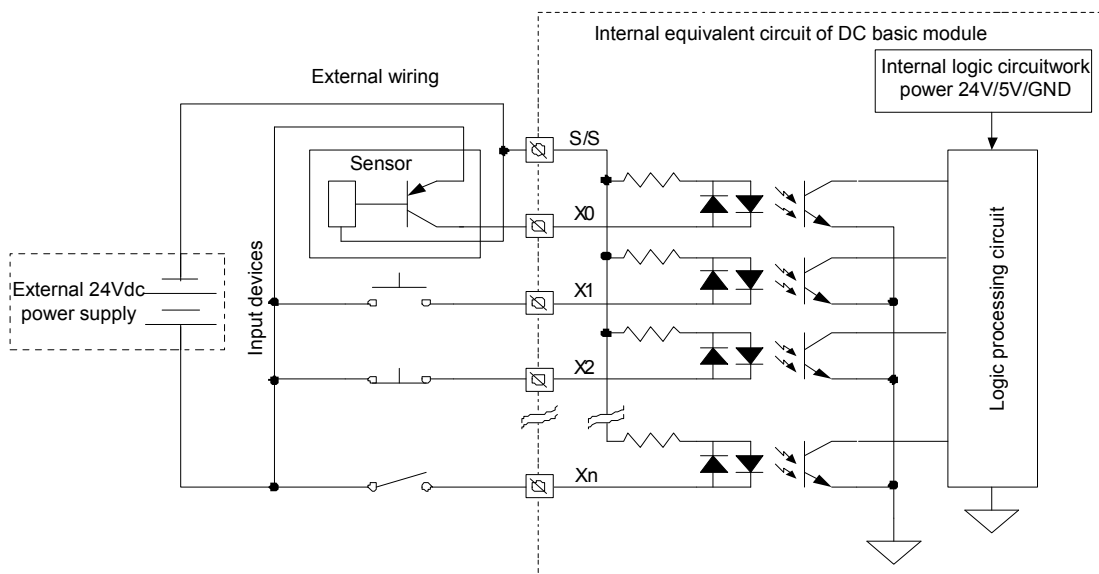

Figure 4-13 Sink input mode internal equivalent circuit of DC basic module

You can also connect in the source input mode by connecting the S/S terminal with COM or the negative input of external 24Vdc power supply, which enables you to connect PNP type sensor. The internal equivalent circuit and external wiring of source input mode are shown in Figure 4-14 and Figure 4-15. The specific external wiring mode is introduced in 4.2.3 *Wiring Of Source Input And Sink Input*.

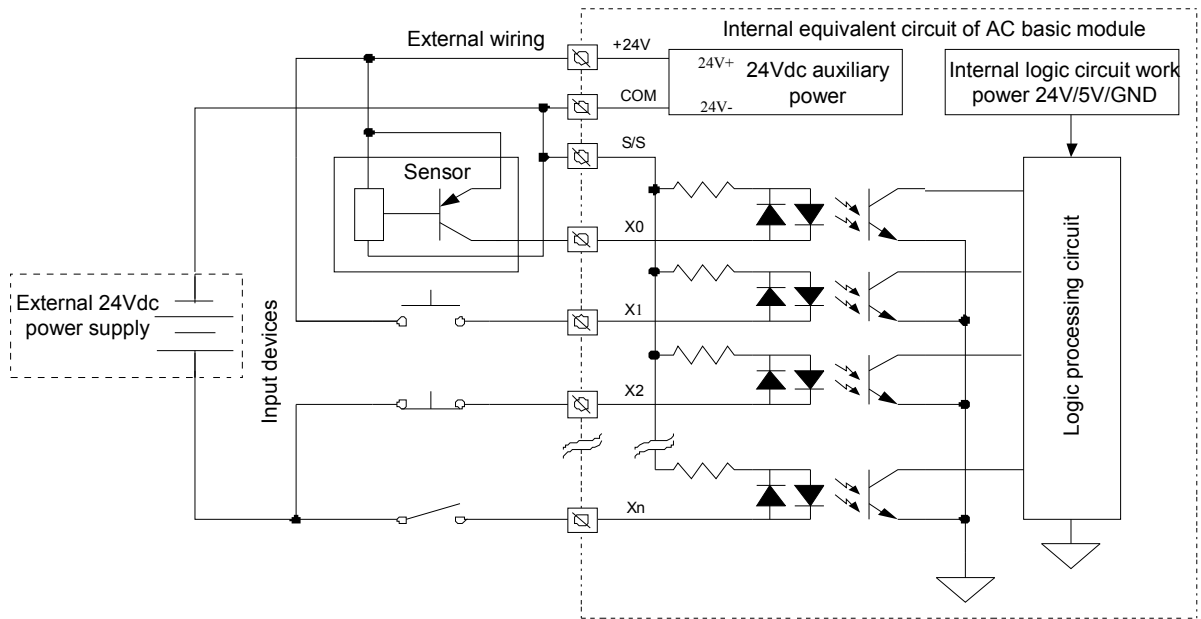

Figure 4-14 Source input mode internal equivalent circuit of AC basic module

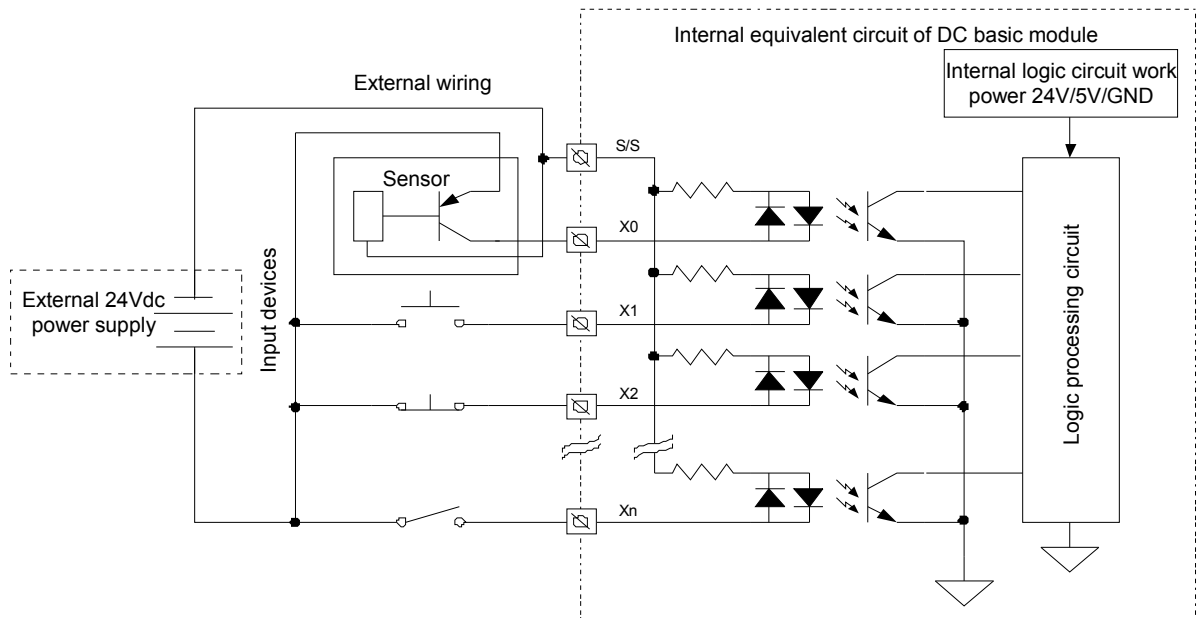

Figure 4-15 Source input mode internal equivalent circuit of DC basic module

Note that in the basic module, all input terminals should use the same input mode, either the source mode or the sink mode. If you feel uncertain about the connection mode, contact your supplier, lest the equipment should be damaged. The internal equivalent circuit and external wiring mode of I/O extension module are shown in Figure 4-16. For detailed information about the external wiring mode, see 4.2.3 *Wiring Of Source Input And Sink Input*.

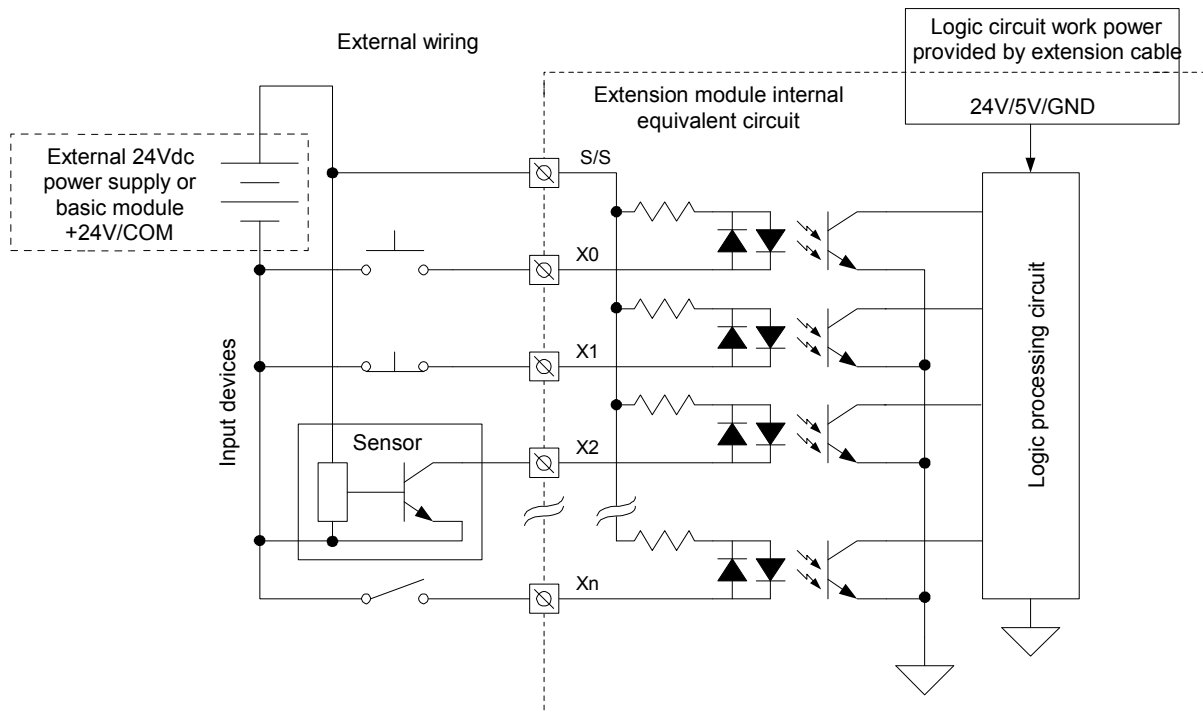

Figure 4-16 I/O extension module internal equivalent input circuit

4.3.3 Wiring Of Source Input And Sink Input

The selection of input mode is determined by the sensor type: source input mode for PNP type sensor, sink input mode for NPN type sensor, and both input modes are all right for dry contact.

The wiring of source input mode using module internal power for AC basic module is shown in Figure 4-17.

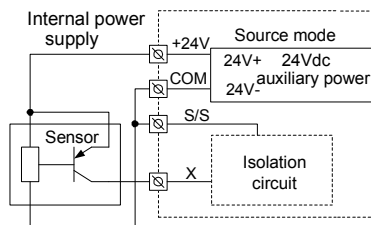

Figure 4-17 Wiring of source input mode using module internal power

The wiring of source input mode using external 24Vdc power for AC basic module is shown in Figure 4-18.

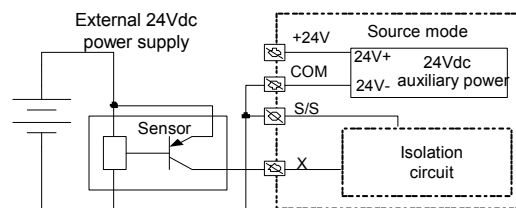

Figure 4-18 Wiring of source input mode using external auxiliary power

The wiring of sink input mode using module internal power for AC basic module is shown in Figure 4-19.

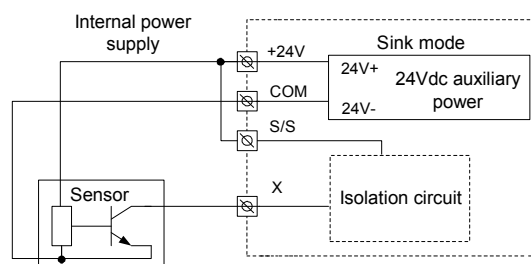

Figure 4-19 Wiring of sink input mode using module internal power

The wiring of sink input mode using external 24Vdc power for AC basic module is shown in Figure 4-20.

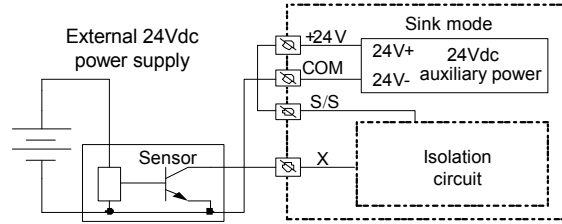

Figure 4-20 Wiring of sink input mode using external auxiliary power

The wiring of source input mode for DC basic module is shown in Figure 4-21.

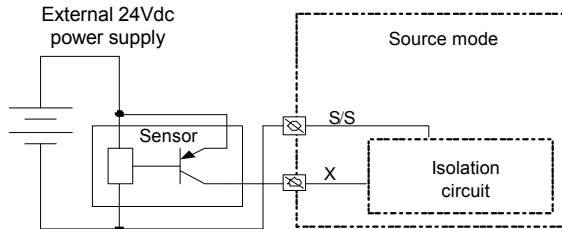

Figure 4-21 Wiring of source input mode for DC basic module

The wiring of sink input mode for DC basic module is shown in Figure 4-22.

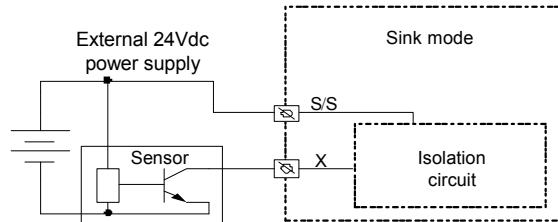

Figure 4-22 Wiring of sink input mode for DC basic module

4.3.4 Input Connection Example

Shown in Figure 4-23 is an example of an IVC1-1614MAR in connection with an IVC1-0808ENR, which realizes simple positioning control. The position signal that PG obtained is detected by high speed counting terminals X0 and X1, the limit switch signal requiring fast response can be input through the high-speed terminals X2 ~ X7, and other user signals can be distributed at input terminals.

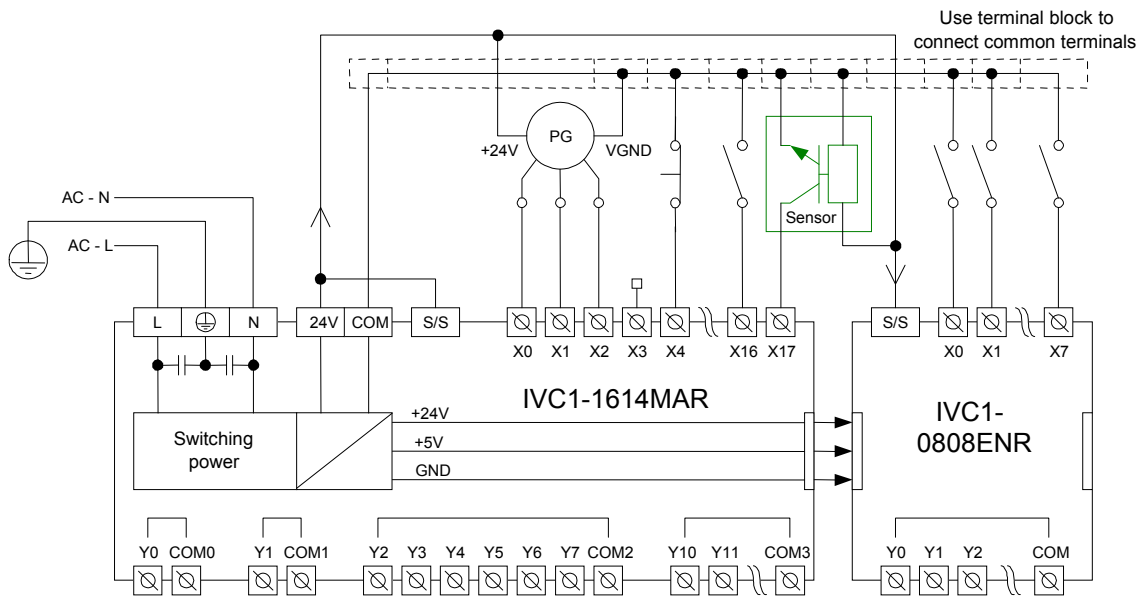

Figure 4-23 Electric connection of IVC1-1614MAR and IVC1-0808ENR

4.3.5 Interrupt Function Of Input

In applications where instant response to the input signal should be made, the interrupt mode can be used. The rising & falling edge of X0 ~ X7 input terminals correspond respectively to an interrupt, altogether 16 external interrupt sources.

If an input port is used as an interrupt, the corresponding interrupt flag should be enabled and the corresponding interrupt subprogram should be programmed. Pay attention to the following points:

- When using interrupt, the digital filter function of corresponding input port will be disabled and the filter time of the corresponding port is set as zero automatically.
- When used as high-speed count input or interrupt input, the corresponding input port should use shielded twisted-pair, with the shielding grounded (connected to ⊕ terminal or signal ground) to improve EMC.
- Some counters require multiple X input ports (for example, C242, C244, and C254 consist of 2, 3, 4 ports separately, as shown in Table 4-8). The ports of this kind of counter cannot be used by other counters, nor be used in common input mode.
- The maximum frequency of the counter input port is limited. Frequencies above that limit may result in incorrect counting or abnormal system operation. Properly arrange the input port and select suitable external sensors.

4.3.6 High-speed Counting Function

The counter vs. X0 ~ X7 terminals relationship is shown in Table 4-13.

Table 4-13 Counter connection mode and features realized through X0 ~ X7

Counter		Input point								Highest frequency (kHz)
		X0	X1	X2	X3	X4	X5	X6	X7	
Single-phase single terminal counting input mode	Counter C236	Up / Down								50
	Counter C237		Up / Down							50
	Counter C238			Up / Down						10
	Counter C239				Up / Down					
	Counter C240					Up / Down				
	Counter C241						Up / Down			
	Counter C242	Up / Down		Reset						
	Counter C243				Up / Down		Reset			
	Counter C244	Up / Down		Reset				Start		
	Counter C245				Up / Down		Reset		Start	
Single phase Up / Down counting input mode	Counter C246	Up	Down							50
	Counter C247	Up	Down	Reset						10
	Counter C248				Up	Down	Reset			
	Counter C249	Up	Down	Reset				Start		
	Counter C250				Up	Down	Reset		Start	
Dual phase Up / Down counting input mode	Counter C251	Phase A	Phase B							30
	Counter C252	Phase A	Phase B	Reset						5
	Counter C253				Phase A	Phase B	Reset			
	Counter C254	Phase A	Phase B	Reset				Start		
	Counter C255				Phase A	Phase B	Reset		Start	

Phase A: phase A input terminal of dual phase counter. Phase B: phase B input terminal of dual phase counter

4.4 Digital Output

4.4.1 Use Of Output

1. The output of IVC1 series PLC is divided into relay type and transistor type. The two have quite different parameters. It is necessary to distinguish them so as to avoid misuse.
2. If the load is inductive (like the relay coil), in a DC output, you need to parallel connect the user circuit with a fly-wheel diode; in an AC output, you need to parallel connect the user circuit with RC surge absorbing circuit so as to protect the PLC output relay contact. Generally no capacitive load should be connected to the relay output terminal. However, if that is unavoidable, make sure the surge is smaller than the max. current explained in Table 4-15.

3. The transistor output terminal must comply with the maximum current limit (as the one in Table 4-15) to prevent over-heating the output terminal. If more than one transistor-terminals output current larger than 100mA, distribute them evenly on the output terminal instead of putting them close to each other, which is bad for ventilation.
4. It is recommended that the number of output channels that are on at the same time should not always exceed 60% of the total number.

The comparison between relay output and transistor output is shown in Table 4-14.

Table 4-14 Relay output vs. transistor output

Item	Relay output	Transistor output
Output mode	Output when in ON state, or no output when in OFF state	
Common terminal	The groups has one common terminal COMn that fit control circuit of different levels. The COMs are isolated from each other	
Voltage feature	220Vac; 24Vdc, no polarity requirement	24Vdc, correct polarity required
Current requirement	Accord with output electric specification (see Table 4-10)	
Overall difference	High driving voltage, large current	Small driving current, high frequency, long lifespan
Application	Loads with low action frequency such as intermediate relay, contactor coil, and LEDs	Loads with high frequency and long life, such as control servoamplifier and electromagnet that act frequently

4.4.2 Output Specification

The digital output specification of IVC1 series PLC basic module are listed in Table 4-15.

Table 4-15 Output specification

Item	Relay output	Transistor output
External power	≤250Vac, ≤30Vdc	5 ~ 24Vdc
Circuit isolation	By relay	Photocoupler
Operation indication	Relay output contacts closed, LED on	LED is on when optical coupler is driven
Leakage current of open circuit	/	Less than 0.1mA/30Vdc
Minimum load	2mA/5Vdc	5mA (5~24Vdc)
Max. output current	Resistive load	Y0, Y1: 0.3A/1 point; Others: 0.3A/1 point, 0.8A/4 point, 1.2A/6 point, 1.6A/8 point. Above 8 points, total current increases 0.1A at each point increase
	Inductive load	Y0, Y1: 7.2W/24Vdc Others: 12W/24Vdc
	Illumination load	Y0, Y1: 0.9W/24Vdc Others: 1.5W/24Vdc
Response time	ON-OFF	20ms Max Y0, Y1: 10us Others: 0.5ms
	OFF-ON	
Y0, Y1 max. output frequency	/	Each channel: 100kHz
Output common terminal	Y0-COM0; Y1-COM1. After Y2, every 8 terminals use one isolated common terminal	
Fuse protection	No	

4.4.3 Output Terminal Internal Equivalent Circuit

The output terminal internal equivalent circuit of relay output type PLC is shown in Figure 4-24.

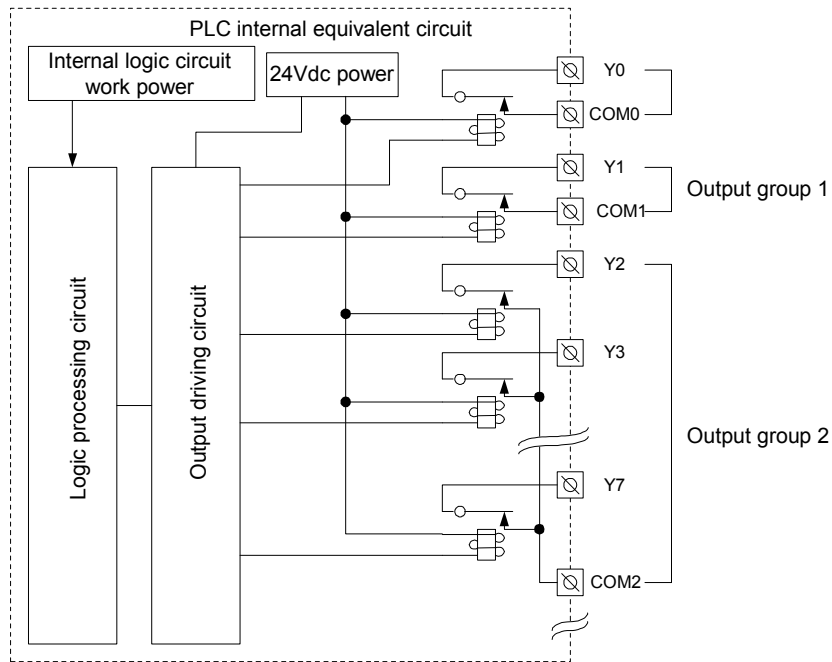

Figure 4-24 Output terminal internal equivalent circuit of relay output type PLC

As shown in the figure, the output terminals are divided into inter-isolated groups. The output contacts of different groups are in connection with different power circuits. When the inductive load is in AC circuit, it should be protected with RC transient voltage absorbing circuit; when in DC circuit, it should be protected with fly-wheel diode, as shown in Figure 4-25.

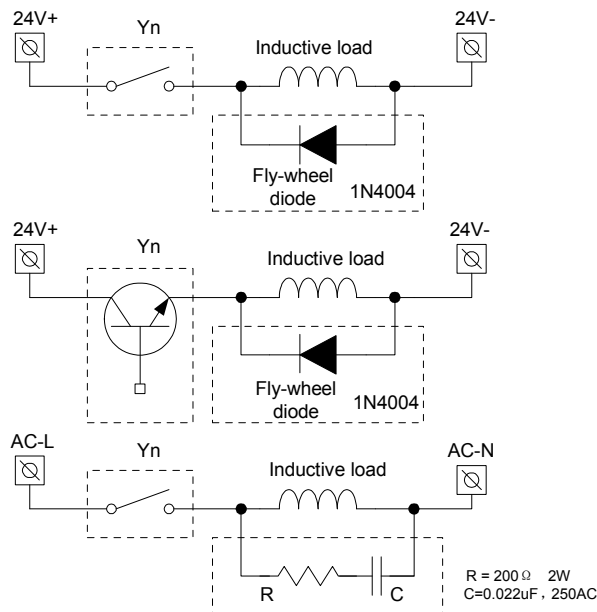

Figure 4-25 Protection circuit of PLC output contact

The output terminal internal equivalent circuit of transistor output type PLC is shown in Figure 4-26.

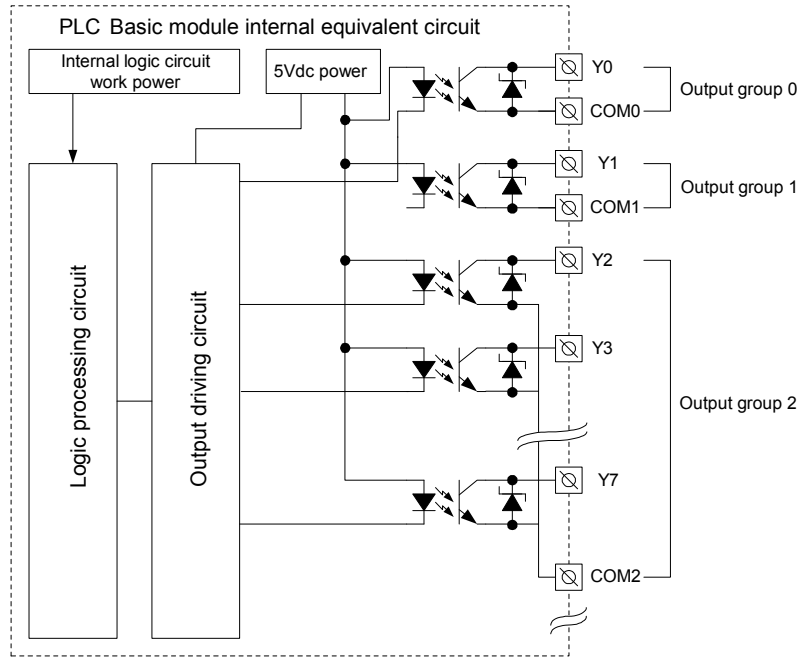

Figure 4-26 Output terminal internal equivalent circuit of transistor output type PLC

As shown in the figure, the output terminals are divided into inter-isolated groups. The output contacts of different groups can be connected with different power circuits. The transistor output can but be used only in 24Vdc load circuit, and you need to mind the polarity of the power supply. When driving an inductive load, it should be protected with a fly-wheel diode, as shown in Figure 4-25.

4.4.4 Output Connection Example

Figure 4-27 shows the connection between an IVC1-1614MAR and an IVC1-0808ENR. Different output groups can connect different signal voltage circuits. Some output groups (like Y0-COM0) are connected to the 24Vdc circuit, and powered by the local 24V/COM; some other groups (like Y1-COM1), to the 5Vdc circuit; and others (like Y2 ~ Y7), to the 220Vac circuit. This is a demonstration of how different output groups can use circuits of different voltage.

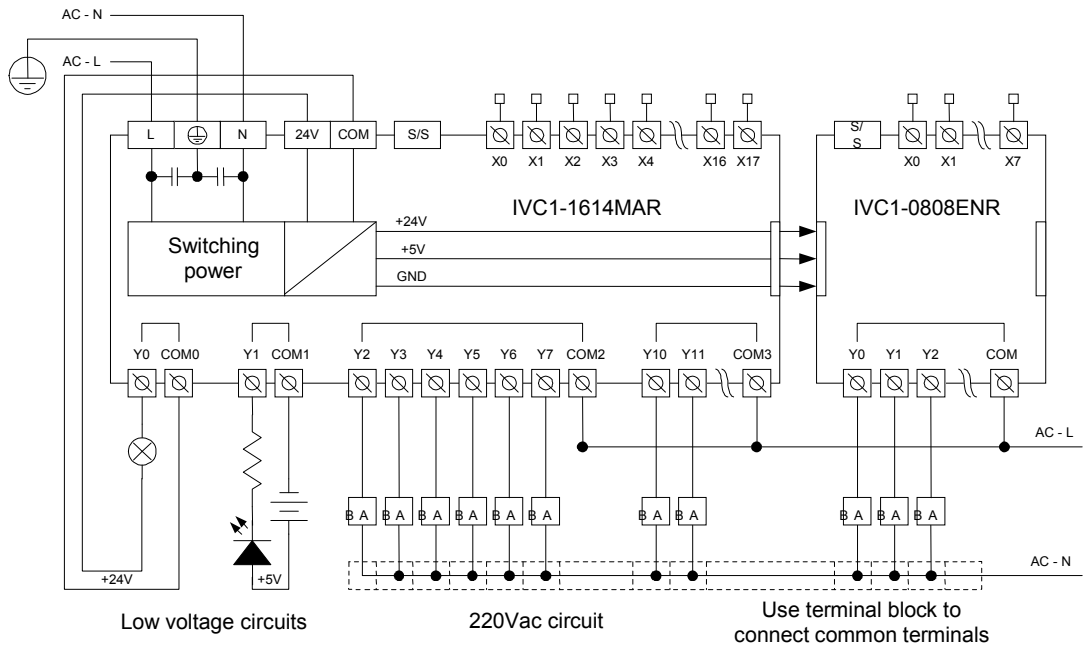

Figure 4-27 Electric connection between IVC1-1614MAR and IVC1-0808ENR

4.4.5 Special Function Of Output

The transistor output basic module comprises two high-speed output terminals: Y0 and Y1, both of which can output high-speed pulses independently. When a terminal outputs high-speed pulses, it is recommended to use shielded twisted pair (with shield grounded to terminal ⊕ or signal ground) as the input cable to improve EMC. The high-speed output frequency can reach 100kHz, and provide high-speed I/O instruction and positioning instruction to manage the high-speed output channel. For details, see *EC Series Small PLC Programming Manual*.

4.5 Input/Output Status Indicator

The status indicator displays the digital input and output status, as shown in Figure 4-28.

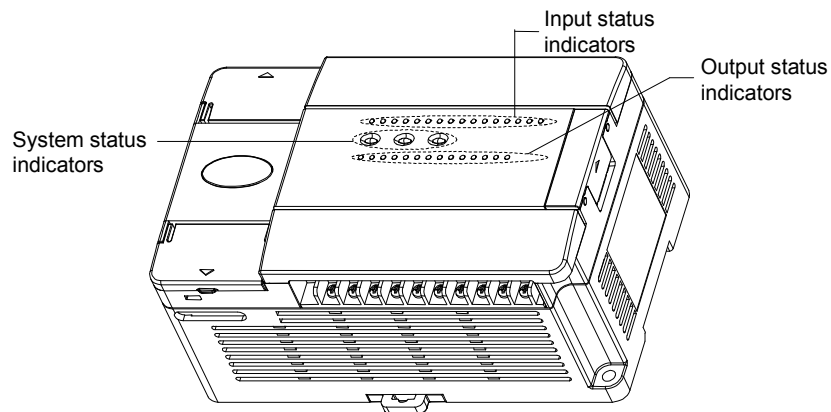

Figure 4-28 Basic module status indicator position

The input status indicator turns on when the input terminal is closed (ON state). Otherwise, the indicator is off.

The output status is displayed by the output status LED, which turns on when the output terminal is closed (ON state, or when Yn and COMn is looped). Otherwise, the indicator is off.

4.6 Analog Input & Output

4.6.1 Usage Of Analog Signal Terminal

IVC1 series PLC also provides AD/DA function that constitutes a small-scale and inexpensive solution for users who need to control analog signal. The models that support analog I/O are listed in Table 4-16.

Table 4-16 IVC1 series PLC models that supports analog I/O

Model	Analog input			Analog output		
	Channel number	Voltage input	Current input	Channel number	Voltage output	Current output
IVC1-1614MAR1	2	Yes	Yes	1	Yes	Yes
IVC1-1614MAT1	2	Yes	Yes	1	Yes	Yes

The preceding text has introduced the terminal position and definition of IVC1-1614MAR1 and IVC1-1614MAT1. The detailed description of analog I/O terminals is shown in Table 4-17.

Table 4-17 IVC1-1614MAR1 and IVC1-1614MAT1 analog I/O terminal definition

	Terminal	Description		Terminal	Description
Analog input	AV1+	Input channel 1: voltage input	Analog signal output	AVO+	Output channel: voltage output
	AI1+	Input channel 1: current input		AIO+	Output channel: current output
	AV1-	Input channel 1: common GND		AO-	Output channel: common GND
	AV2+	Input channel 2: voltage input			
	AI2+	Input channel 2: current input			
	AVI2-	Input channel 2: common GND			

Note: The voltage input and current input cannot use the same channel at the same time. To measure the current signal, short the voltage input terminal and current input terminal

The internal equivalent circuit of the analog signal I/O part is shown in Figure 4-29.

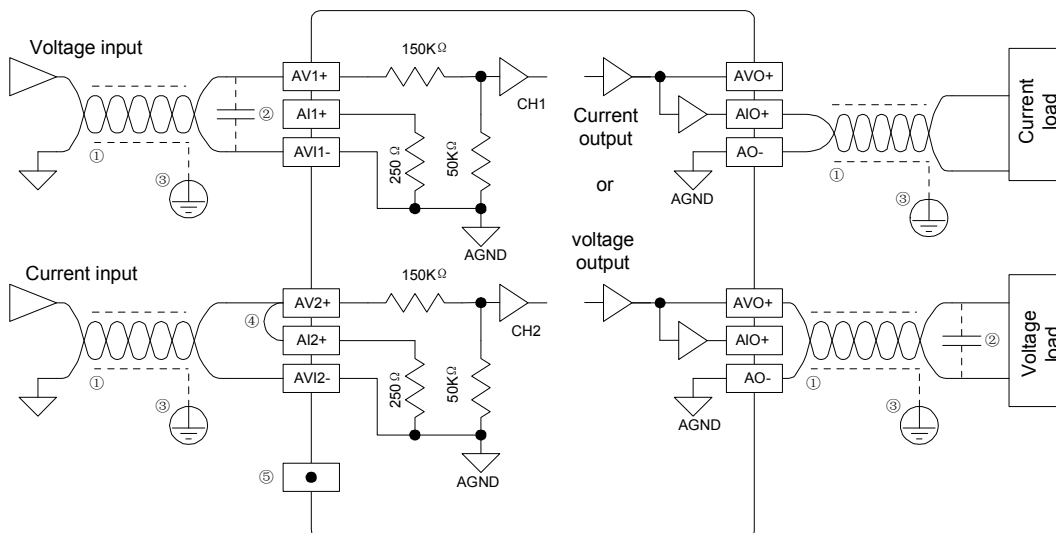

Figure 4-29 Internal equivalent circuit of analog I/O

Refer to Figure 4-29 for the wiring, and note the following eight points:

1. Use shielded twisted pair for the analog input and output. The signal cable should be away from power cables or any cable that may generate EMI.
2. If the signal I/O is affected by electric noise or voltage fluctuation, you can connect to the cable a capacitor (0.1 μ F ~ 0.47 μ F/25V). A ceramic capacitor is recommended.
3. If the electric interference is strong, ground the cable shield.
4. If the present channel inputs current, short its voltage input terminal and current input terminal.
5. Do not use the suspended pin on the user terminal.
6. The PLC could be damaged if the voltage output is shorted, or if a current load is connected to a voltage output.
7. Properly ground the module GND terminal ⊕.
8. Use single-point grounding at the load end of the output cable.

4.6.2 Analog I/O Specification

The specification of analog I/O is shown in Table 4-18.

Table 4-18 Analog I/O specification

Item		Specification
Max. conversion speed	AD conversion	2 channels, totally 4ms
	DA conversion	4ms/channel
Analog input range	Voltage input	-10 ~ 10Vdc (input impedance ≥200kΩ), input signal freq. <10Hz. Warning: the unit could be damaged with input voltage >±15Vdc
	Current input	-20 ~ 20mA (input impedance: 250Ω), input signal freq. <10Hz. Warning: the unit could be damaged with input voltage >±30mA
Analog output range	Voltage output	-10~10Vdc(external load impedance: 2kΩ~1MΩ)
	Current output	0 ~ 20mA (external load impedance: ≤500Ω)
Digital I/O range		-10000 ~ 10000
Resoultion	Voltage input	5 mV
	Current input	10 μ A
	Voltage output	5mV
	Current output	10 μ A
Overall precision	Analog input	DC -10 ~ 10V, -20 ~ 20mA: ±1%
	Analog output	±1%
Isolation		Between analog circuit and digital circuit: optical coupler. Between analog channels: none

4.6.3 Analog Terminal Configuration

The special data registers that are accessible to analog terminals are defined in Table 4-19. For detailed information, see *IVC1 Series PLC Programming Manual*.

Table 4-19 Data registers accessible to analog terminals

Address	Name	R/W	Range
SD172	Average sample value of A/D channel 0	R	-10000 ~ 10000
SD173	Sampling times of A/D channel 0	R/W	1 ~ 1000
SD174	Average sample value of A/D channel 1	R	-10000 ~ 10000
SD175	Sampling times of A/D channel 1	R/W	1 ~ 1000
SD178	Output value of D/A channel 0	R/W	-10000 ~ 10000

Note: the default of SD173 and SD175 is 8

Chapter 5 Communication And Networking

5.1 Communication Port

IVC1 series PLC basic module provides two serial asynchronous communication ports, namely PORT0 and PORT1. The specification of the communication ports is shown in Table 5-1.

Table 5-1 IVC1 series basic module communication port specification

Port	Socket type	Signal level	Work mode	Protocol	Application	Supported baud rate (bps)
PORT0	Mini DIN8	RS232	Full duplex	Programming protocol	User programming, debugging and monitoring	9600 and 19200
				MODBUS slave station	Work in connection with HMI, or work as a slave station through networking	38400, 19200, 9600, 4800, 2400, 1200
				Free-port protocol	User defined	38400, 19200, 9600, 4800, 2400, 1200
				N:N NETWORK protocol*	Sharing of partial data with other PLCs in the network	115200, 57600, 38400, 19200, 9600, 4800, 2400, 1200
PORT1	EK500V	RS232 and RS485 optional	RS232 full duplex, RS485 half duplex	MODBUS master station	Work as master station through networking to control other equipment	38400, 19200, 9600, 4800, 2400, 1200
				MODBUS slave station	Work as slave station through networking, or work in connection with HMI	38400, 19200, 9600, 4800, 2400, 1200
				Free-port protocol	User defined	38400, 19200, 9600, 4800, 2400, 1200
				N:N NETWORK protocol	Sharing of partial data with other PLCs in the network	115200, 57600, 38400, 19200, 9600, 4800, 2400, 1200

The communication protocol of PORT0 is selected through the mode selection switch, as shown in Figure 5-1.

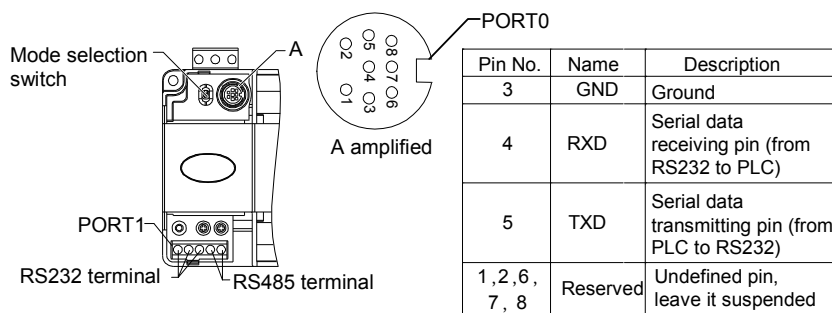

Figure 5-1 Communication port and mode selection switch

As a dedicated port for user programming, PORT0 can be switched to programming protocol through the mode selection switch. The PLC operation status vs. PORT0 protocol switching is shown in Table 5-2.

Table 5-2 PORT0 protocol mode switching

Mode selection switch setting	Status	PORT0 protocol
ON	Running	Programming protocol, or Modbus protocol, or Free-port protocol, or N: N network protocol (N:N NETWORK), as determined by user program and system configuration
TM (ON → TM)	Running	Converted to programming protocol
TM (OFF → TM)	Stop	
OFF	Stop	If the system configuration of user program is Free-port protocol, it converts to programming protocol automatically after stop; or system protocol keeps unchanged

PORT1 is ideal for connection with equipment that can communicate (such as inverters). With Modbus protocol or RS485 terminal free protocol, it can control multiple devices through a network.

Its terminals are fixed with screws. You can use a shielded twisted-pair as the signal cable to connect communication ports by yourself.

Note: Never use RS232 terminal and RS485 at the same time. Besides, suspend the unused terminals, or communication could be interrupted.

5.2 Programming Environment

5.2.1 Auto Station Programming Tool

The editing and downloading of the IVC1 series PLC user program needs INVT Auto Station integrated software. The Auto Station programming software can run on the personal computer. OS: Microsoft Windows 98, Me, NT 4.0, Windows 2000 or XP. The minimum hardware requirements are listed in Table 5-3.

Table 5-3 Hardware requirements of IVC1 series PLC programming software

Item	Min. configuration	Recommended configuration
CPU	Intel Pentium 233 or above	Intel Pentium 1G or above
Memory	64M	128M
Graphics card	640 × 480 and 256 colors	800 × 600 and 65535 colors
Communication port	A RS232 serial communication port with DB9 output socket	
Others	INVT PLC dedicated programming cable	

The integrated Auto Station program system is compatible with IEC61131-3 standard. Ladder diagram, instruction list, and sequential function chart can be used to program. Besides, the unit has such functions as up/downloading, monitoring, debugging, and on-line modifying. The software also provides practical instruction guide and on-line help. For details, see *Auto Station Programming Software User Manual*.

5.2.2 Programming Cable

INVT provides a serial communication cable to download programs. The two ends of the cable are Mini-DIN8 and DB9 respectively. The cable models are listed in Table 5-4.

Table 5-4 PLC programming cable model

Model	Name	Length	Description
SL1	Normal programming cable	2m	Non-isolation design, not hot swappable.
SL2	Isolation programming cable	2m	Electrically isolated ends, hot swappable, with better EMS

Chapter 6 Installation

6.1 Safe Precaution



Danger

The PLC is applicable to locations that meet Installation category II and Pollution Degree 2 (IEC 61131). The installation environment should be free from dust, oil smoke, conductive particle, corrosive or flammable gases, high temperature, condensation, and rain. Besides, vibration and impact also affect the PLC normal operation and shorten its lifespan.

It is recommended to install the PLC, together with the matching switches and contactors, in a dedicated electric cabinet and keep the cabinet ventilated. If the location has high ambient temperature or heat generating equipment nearby, install forced convection devices on top or sides of the cabinet to avoid over-temperature.

During drilling or wiring, prevent the metal particles or wire segments from falling into the PLC casing, which may cause fire, fault or misact.

After the PLC installation, clean the ventilation duct to prevent blocking, which may cause bad ventilation, or even fire, faults or misact.

Do not online connect, plug or unplug cables, which is apt to cause electric shock or damage the circuit.

Installation and wire connection must be firm and reliable. Poor connection could cause misact.

6.2 Installation Sizes

6.2.1 IVC1-1006MA/DR, IVC1-1006MA/DT

The sizes and installation holes of IVC1-1006MAR, IVC1-1006MAT, IVC1-1006MDR and IVC1-1006MDT are shown in Figure 6-1.

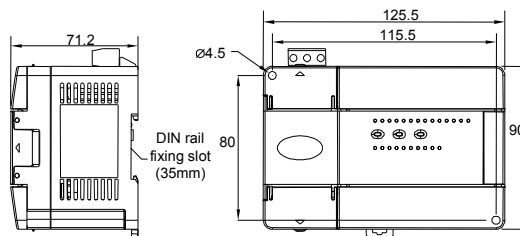

Figure 6-1 Cutout sizes of IVC1-1006MAR and IVC1-1006MAT, IVC1-1006MDR and IVC1-1006MDT

6.2.2 IVC1-1410MA/DR, IVC1-1410MA/DT

The sizes and installation holes of IVC1-1410MAR, IVC1-1410MAT, IVC1-1410MDR and IVC1-1410MDT are shown in Figure 6-2.

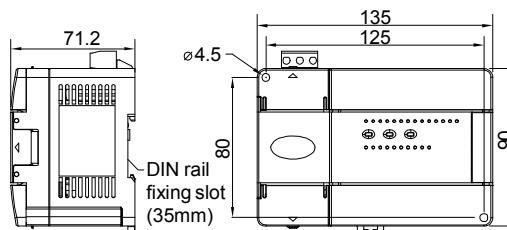

Figure 6-2 Cutout sizes of IVC1-1410MAR, IVC1-1410MAT, IVC1-1410MDR and IVC1-1410MDT

6.2.3 IVC1-1614MA/DR, IVC1-1614MA/DT

The sizes and installation holes of IVC1-1614MAR, IVC1-1614MAT, IVC1-1614MDR and IVC1-1614MDT are shown in Figure 6-3.

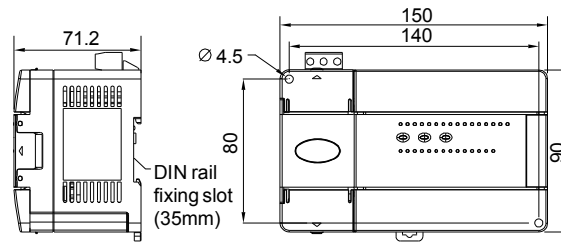

Figure 6-3 Cutout sizes of IVC1-1614MAR, IVC1-1614MAT, IVC1-1614MDR and IVC1-1614MDT

6.2.4 IVC1-2416MA/DR, IVC1-2416MA/DT, IVC1-1614MAR1 And IVC1-1614MAT1

The sizes and installation holes of IVC1-2416MAR, IVC1-2416MAT, IVC1-2416MDR, IVC1-2416MDT, IVC1-1614MAR1 and IVC1-1614MAT1 are shown in Figure 6-4.

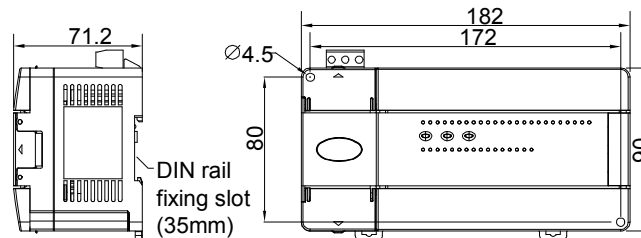

Figure 6-4 Cutout sizes of IVC1-2416MAR, IVC1-2416MAT, IVC1-2416MDR, IVC1-2416MDT, IVC1-1614MAR1 and IVC1-1614MAT1

6.2.5 IVC1-3624MA/DR, IVC1-3624MA/DT

The sizes and installation holes of IVC1-3624MAR, IVC1-3624MAT, IVC1-3624MDR and IVC1-3624MDT are shown in Figure 6-5.

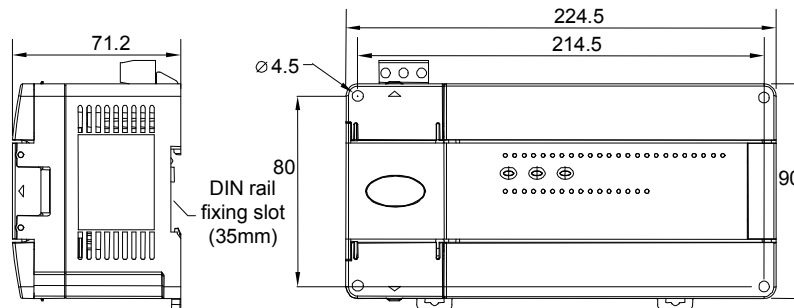

Figure 6-5 Cutout sizes of IVC1-3624MAR, IVC1-3624MAT, IVC1-3624MDR and IVC1-3624MDT

6.2.6 Extension Module

The sizes and installation holes of I/O extension modules IVC1-0808ENR, IVC1-0808ENT, IVC1-0800ENN, are shown in Figure 6-6, which are the same as special function modules IVC1-4AD, IVC1-4DA, IVC1-5AM, IVC1-4TC and IVC1-4PT.

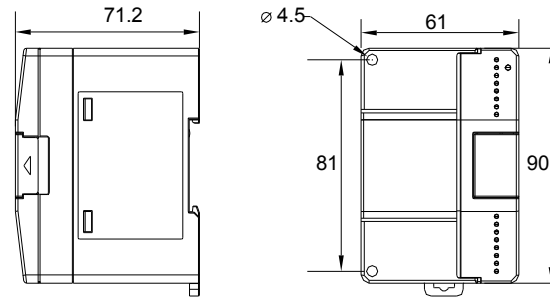

Figure 6-6 Cutout sizes of I/O extension module and special function module

6.3 Mechanical Installation

6.3.1 Location

The PLC must be installed horizontally on cabinet backboard, as shown in Figure 6-7.

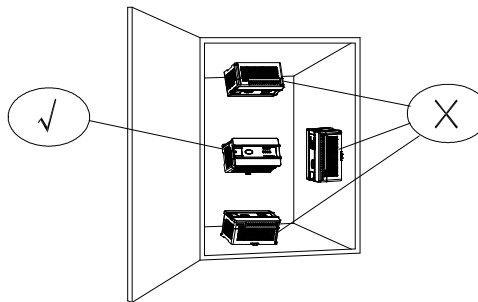

Figure 6-7 Installation position

As shown in the figure, the only correct installation position is to put the PLC long side horizontal, which is ideal for air flow. Keep at least 15cm of clearance respectively at the top and bottom of the PLC, and do not put any heat-generating devices below.

6.3.2 Procedures

DIN rail mounting

Use the 35mm-wide DIN rail for the installation, as shown in Figure 6-8.

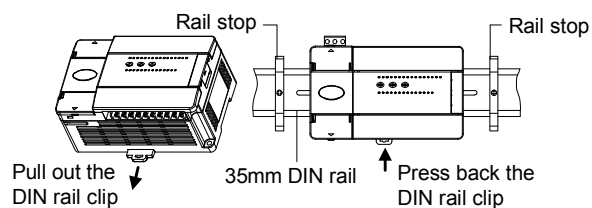

Figure 6-8 DIN rail installation

Follow the following procedures:

1. Fix the DIN rail to the backboard.
2. Pull out the clip on the bottom of the PLC.
3. Hook the back of the PLC onto the rail.
4. Push back the clip, make sure PLC has been fastened to the rail.
5. At last, mount two rail-stops at the two sides to avoid sliding.

Screw fixing

Fixing the PLC with screws can stand greater shock than rail mounting. Use M3 screws through the $\Phi 4$ mounting holes on PLC enclosure to fix the PLC onto the backboard of the electric cabinet, as shown in the following figure.

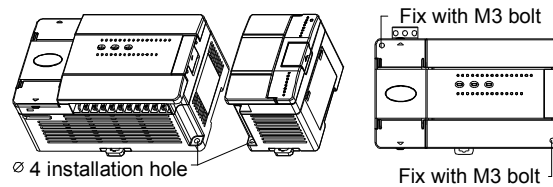

Figure 6-9 Screw fixing

6.4 Wiring

6.4.1 Precautions



Danger

1. Do not use PLC in a environment with dust, oil smoke, conductive particle, corrosive gases, flammable gases, high temperature, condensation, rain water, vibration and impact. Electric shock, fire and mis-operation will also damage the PLC.
2. During drilling or wiring, prevent the metal particles or wire segments from falling into the PLC casing, which may cause fire, fault or misact.
3. After the wiring, clean the PLC and put the terminal covers in position before power on to avoid electric shock.
4. After the PLC installation, clean the ventilation duct to prevent blocking, which may cause bad ventilation, or even fire, faults or misact.
5. Do not online connect, plug or unplug cables, which is apt to cause electric shock or damage the circuit.
6. Installation and cable connection must be firm and reliable. Poor connection could cause misact.
7. Use shielded twisted pair for the transmission of analog and high frequency signals to improve system IMS.
8. Input AC power through the L and N terminals as stipulated in this manual. Misconnection of the AC power will ruin the PLC.
9. Do not use external power to feed the +24V terminal of the basic module, or the module will be damaged.
10. Do not lay the PLC input & output signal cables parallel with power cables or cables with strong interference.
11. Do not share a GND between the basic module and a power system.

6.4.2 Cable Specification

When wiring a PLC, use multi-strand copper wire and ready-made insulated terminals to ensure the quality. The recommended model and the cross-sectional area of the cable are shown in the following table.

Table 6-1 Recommended PLC cable models

Wire	Cross-sectional area	Recommended model	Cable lug and heat-shrink tube
AC power cable (L, N), DC power cable (24V+, 24V-)	1.0 ~ 2.0mm ²	AWG12, 18	H1.5/14 round insulated lug, or tinned cable lug
Earth cable (⊕)	2.0mm ²	AWG12	H2.0/14 round insulated lug, or tinned cable end
Input signal cable (X)	0.8 ~ 1.0mm ²	AWG18, 20	UT1-3 or OT1-3 solderless lug, Φ3 or Φ4 heat shrinkable tube
Output signal cable (Y)			

The recommended cable processing-method is shown in the following figure.

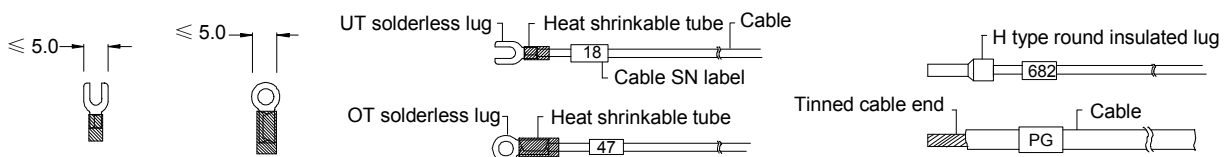

Figure 6-10 PLC cable processing method

Fix the prepared cable head onto the PLC terminals with screws. Fastening torque: 0.5 ~ 0.8Nm.

6.4.3 Connecting Power Cables

Note

The power supply input is an accessory to the basic module. You should offline connect the power cable to the power supply input and insert the power supply into PLC basic module.

Danger

1. There are two kinds of IVC1 series PLCs in terms of their input powers: 220Vac and 24Vdc. Make sure the power input is correct before wiring and power on.
2. PLC is applicable to control circuits, and there should be lightning protection devices in its AC power circuit. Separate the PLC power circuit from the power circuit of other equipment to avoid operation over-voltage.
3. Do not input the AC power or DC power to the 24Vdc output terminal of the basic module.
4. Do not online connect, plug or unplug the cable to avoid electric shock and damaging the equipment.
5. Make sure the power supply input is connected firmly to the PLC basic module, lest there should be electric shock or damage due to loosened terminals.

Connect the power cables according to Figure 6-11.

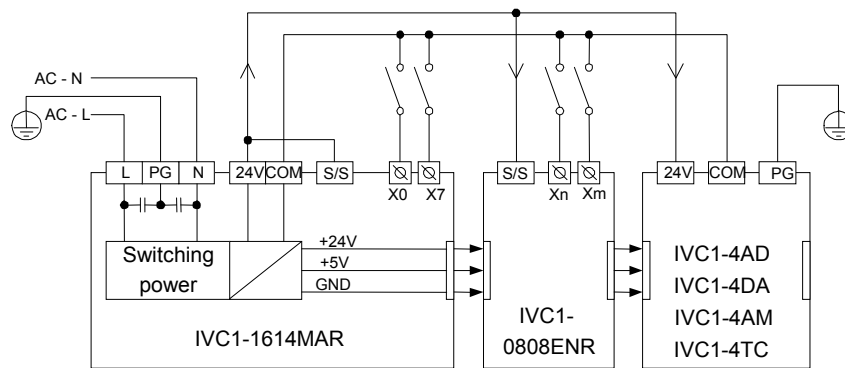

Figure 6-11 Connecting AC power and auxiliary power

6.4.4 Connecting GND Cables

A reliable GND cable can improve PLC safety and IMS. During the installation, connect the PG terminal of PLC power input with the ground electrode. It is recommended to use the AWG12~16 cable, keep it as short as possible, and use an independent grounding device. Avoid sharing common routes with the ground cable of other equipment (especially those with strong interference), as shown in the following figure.

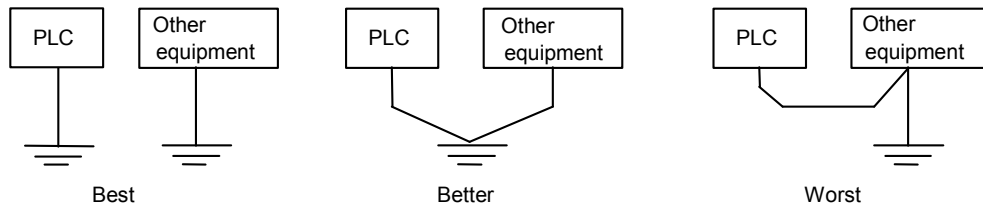

Figure 6-12 PLC grounding method

If PLC extension modules are used, connect the ground cable of each module to the ground electrode separately, as shown below.

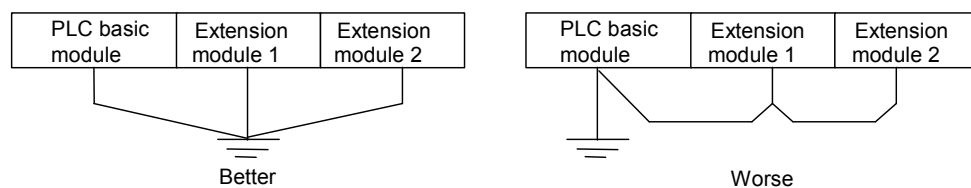

Figure 6-13 Grounding of PLC basic module and extension modules

6.4.5 Connecting Input And Output Signal Cables

The wiring of a PLC system may involve connecting multiple cables to the same terminal, such as +24V, COM, output common terminal COMn (see Figure 4-23 and Figure 4-27). In that case, it is recommended to use the extension terminal bar, attached with identifying labels made onsite. Connect the input and output terminals according to the instructions in *Chapter 4 I/O Features*.

6.4.6 Connecting Extension Bus

Before powering on the basic module, remove the cover from the extension cable terminal at the right of the basic module and insert the extension cable of the extension module into the basic module. To connect multiple extension modules, just connect them in the same way one by one. See Figure 6-14.

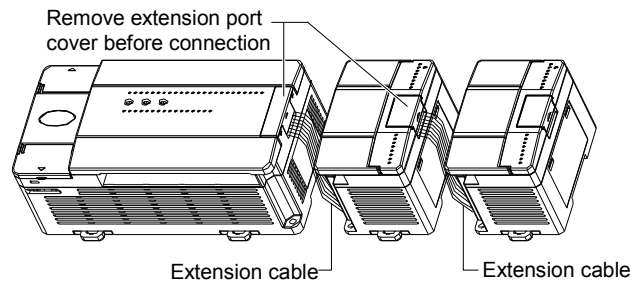

Figure 6-14 Connecting extension module

Note

Pay attention to the direction of the plug during extension module connection and insert gently to avoid damaging the pins.

6.5 Setting Addresses For I/O Channels Of Extension Module

The IVC1 series basic modules can automatically identify the connected extension modules and set their addresses by their connection order.

The extension module address is set upon the first power on and will remain. Do not insert or remove the extension module during operation, otherwise abnormalities may occur.

- The addresses of I/O channels are octal, numbered as 0, 1, ... 7, 10, 11 and so on, without numbers 8 and 9.
- The input terminals of all modules (basic and extension) are numbered as X0, X1, X2, ...X7, X10, X11 and so on, while the output terminals are numbered as Y0, Y1, Y2, ...Y7, Y10, Y11 and so on. Every eight channels forms one group. If the remaining channels are less than 8, the unused numbers will be left unassigned.

For example, in module IVC1-1614BRA, its 16 input channels are numbered as X0 ~ X17, and the next extension module starts from X20. If the module has 14 output channels that are numbered as Y0 ~ Y15, there will be no channels numbered as Y16 or Y17, because the output channels of the next extension module will start from Y20.

The extension modules' I/O channels are numbered in accordance with the module's connection order. See Figure 6-15 for a numbering example.

IVC1-1410MAR	0808ENT	0808ENR	0800ENN
X0~X15	X20~X27	X30~X37	X40~X47
Y0~Y11	Y20~Y27	Y30~Y37	

Figure 6-15 Numbering the extension modules' channels

Chapter 7 First Poweron And O&M

Read the precautions in this manual carefully and strictly follow the instructions during installation and wiring. Check against the safety requirements and confirm the correctness before the power-on.

7.1 Pre-poweron Inspection

1. Make sure that the input power voltage meets the PLC rating, and the power cables are connected to the right terminals. Note that the 220Vac power supply terminals are L and N, while the 24Vdc power supply terminals are 24V+ and 24V-. Do not confuse the power supply terminals with +24V and COM.
2. Make sure that the user input cables are connected to PLC input terminals in accordance with the respective technical specification.
3. Check the output terminals, and make sure that, if the output circuits are of different voltage levels, output terminals of different voltage levels are assigned to different groups, so as to avoid short circuits.
4. Make sure that the connecting method and model of GND cables meet the requirements.
5. Make sure that no alien objects have fallen into the PLC casing, and the ventilation duct is clear.
6. If the host or human machine interface is needed, make sure that the communication cable has been correctly connected.

7.2 Poweron Operation

1. Power on the PLC, and the PLC POWER indicator should turn on.
2. Run the Auto Station software on the host and download the user program to the PLC.
3. After checking the downloaded program, set the mode selection switch to ON, and the RUN indicator should turn on. If the ERR indicator turns on instead, the user program or system must have been faulty. Remove the fault by referring to the *10 Series PLC Programming Manual*.
4. Power on the PLC external system to start system debugging.

7.3 RUN & STOP Status Switchover

7.3.1 Status Description And Mode Selection

The PLC statuses include RUN and STOP. To help users control the system, the basic module provides multiple status control methods, such as mode selection switch, Auto Station software, communication port (like MODBUS), and input terminals X0 ~ X17.

RUN

When the basic module runs, the system will execute the user program, which involves a scanning period including four tasks (executing user program → communication → internal task → refreshing I/O).

STOP

When the basic module is stopped, the system will not execute the user program. Only three of the four tasks in a scanning period will be executed (communication → internal task → refreshing I/O).

Mode selection switch

PLC provides a mode selection switch, which enables you to switch the programming protocol and select running mode. The setting of this switch has been described in Table 5-2. The relationship between the setting of mode selection switch and the PLC status as well as programming protocol is shown in the following table.

Table 7-1 Mode selection switch setting

Present state	Switchover	State afterward	Description
RUN	ON → TM	RUN	PORT0 protocol changes to programming protocol
RUN	TM → ON	RUN	PORT0 protocol changes to the one set in the system block
RUN	TM → OFF	STOP	System stops. Protocol changes in the same way as above row
STOP	OFF → TM	STOP	PORT0 protocol changes to programming protocol
STOP	TM → OFF	STOP	PORT0 protocol changes to the one set in the system block
STOP	TM → ON	RUN	System starts. Protocol changes in the same way as above row

7.3.2 How To Start (STOP→RUN)

Reset mode

When the mode selection switch is set to ON, the system will run automatically once it is powered on.

Note: If the Input Channel Control Mode “Startup mode of the input point” is enabled in the system configuration, the designated input channel should be ON, or the system cannot enter the RUN status. See the following text for detailed description of input channel control mode.

Manual mode

You can run the system in the STOP status by setting the mode selection mode to ON.

Communication mode

A system in the stop status will enter the RUN status after receiving the RUN instruction through communication.

Input channel control mode

In the STOP status, when system detects the OFF → ON change of the designated input terminal, the basic module will enter the RUN status.

Note that when using the input channel control mode, you need to enable the Input Channel Control Mode in system configuration and set the mode selection switch to ON.

7.3.3 How To Stop (RUN→STOP)

Reset mode

When the mode selection switch is set to OFF, the running system will stop automatically once it is reset.

If the Input Channel Control Mode is enabled in the system configuration, the designated input channel should be OFF, or the system cannot be stopped.

Manual mode

You can stop a running system by setting the mode selection switch to OFF.

Communication instruction mode

A running system will stop after receiving the STOP instruction through communication.

Command control mode

A running system will stop after executing the STOP command.

Error stop mode

A running system will stop executing user program after detecting serious errors (such as user program error and user program overtime).

7.4 Routine Maintenance

Note the following during routine maintenance:

- Keep the PLC working environment clean to prevent alien objects from entering the PLC casing.
- Keep the PLC ventilation in good condition.
- Keep all cable connections in good condition.

Chapter 8 Troubleshooting

8.1 Symptom And Handling Method

When abnormalities occur to the PLC, check the following:

1. The power cable connection and related switches & protection devices
2. The user terminals connection
3. The setting of mode selection switch

If the PLC still does not work after checking the preceding items, carry out analysis over PLC status and I/O indicators by referring to Table 8-1.

Table 8-1 Symptom and handling method

Symptom	Possible causes	Handling method
All LEDs are off	Power supply failure or low-voltage	Check the power supply and remove the fault
	Power switch off or fuse broken	Check the related switches, cable or fuses and remove the fault
	Power supply cable connection error	
	Power board damaged	Make sure that: 1. The voltage between terminals L and N is normal 2. No short circuit or too heavy load between 24V and COM terminal
POWER LED blinks	Bad connection of power supply cables	
	Current limit due to too many extension modules connected	
ERR LED blinks	Current limited due to short circuit of 24V/COM auxiliary power output	Use Auto Station to edit user program again, correct the fault and download again
	User program error	
RUN LED is off	Actual run time exceeds WDT set time	Set longer WDT time
	Mode selection switch is not ON	Set the switch to ON
	The operation control mode is set to terminal mode, while the terminals are set OFF	Close the designated operation control terminals
	The host stopped the PLC through communication	Start the PLC through the host
Input status indicator inconsistent with input terminal status	Sysetm stopped upon errors	Check PLC application system
	The on resistance of user cables too big	Correct the external circuit electric parameters. For example, short the cable, or don not use too thin cables
Output cannot be shut off	Bad contact of signal circuit	Check the connection and remove the fault
	Bad connection of external connection	
Status indicator inconsistent with actual output terminal status	Relay contact damaged	You can exchange the relays that act frequently with those that stay idle
	Relay faulty, or indicator damaged	
Unable to download, upload or monitor	Bad cable connection, or incorrect setting of PLC ON/TM/OFF	Use INVT PLC download dedicated communication cable
Serial ports unable to control other equipment	Bad cable connection, or cable signal property wrong, like having TXD and RXD confused	Connect the signal cable correctly
	Master and slave setting inconsistent, including the baud rate, parity check, digit number, and address	Set the communication parameters consistently
	Master and slave use different protocols	Set the communication protocols consistent
I/O extension module not responsive, or special extension module not responsive	Bad connection of extension cable	Power off the check, remove the fault and power on again

Symptom	Possible causes	Handling method
Low speed counting inaccurate	In most cases, it is due to input signal curves being subject to strong interference	Parallel connect a 22uF, 50V capacitor to the counter input terminal. Be careful with the capacitor polarity
	In some cases, it is due to the detected signal cycle being shorter than PLC program execution cycle	If user program execution cycle cannot be shortened, arrange the counting signal at the high speed counter terminal. If it is set to constant scanning, set a proper scanning time

8.2 Error Code

The error codes and types are listed in Table 8-2.

Table 8-2 Error code and type

Error code	Meaning	Error type	Description
0	No error		
1 ~ 19	Reserved		
External setting error (20 ~ 23)	20	Serious I/O error	System error User program stopped. ERR indicator turns on. To remove this fault, power off and check hardware
	21	Extend I/O serious error	System error ERR indicator turns on. This alarm is cleared automatically upon the removal of the fault
	22	Special Module Severe Error	System error ERR indicator blinks. This alarm is cleared automatically upon the removal of the fault
	23	Real time clock error refreshing (wrong time is read during system update)	System error ERR indicator blinks. This alarm is cleared automatically upon the removal of the fault
	24	EEPROM Read and Write Operation Error	System error ERR indicator blinks. This alarm is cleared automatically upon the removal of the fault
	25	Local Analog Value Error	System error ERR indicator blinks. This alarm is cleared automatically upon the removal of the fault
Storage error (40 ~ 45)	40	User program file error	System error User program stopped. ERR indicator turns on. To remove this fault, download new program or format the disk
	41	System configuration file error	System error User program stopped. ERR indicator turns on. To remove this fault, download new system configuration files or format the disk
	42	Data block file error	System error User program stopped. ERR indicator turns on. To remove this fault, download new data block file or format the disk
	43	Battery backup data lost error	System error User program not stopped. ERR indicator blinks. To remove this fault, clear the register, or format the disk, or reset
	44	Forced list lost error	System error User program not stopped. ERR indicator blinks. To remove this fault, clear the register, or force, or format the disk, or reset
	45	User info file loss error	System error User program not stopped. ERR indicator is off. To remove this fault, download new program and data block files, or format the disk, or reset
46 ~ 59	Reserved		

Error code	Meaning	Error type	Description	
Instruction execution error (60 ~ 75)	60	User program compilation error	Execution error	User program stopped. ERR indicator turns on
	61	User program operation overtime error	Execution error	User program stopped. ERR indicator turns on
	62	illegal user program instruction execution error	Execution error	User program stopped. ERR indicator turns on
	63	Illegal element type of instruction operand	Execution error	User program stopped. ERR indicator turns on
	64	Illegal instruction operand value	Execution error	User program keep running. ERR indicator keeps off. The corresponding error code will be prompted in SD20
	65	Outside instruction element range	Execution error	
	66	Subprogram stack overflow	Execution error	
	67	User interrupt request queue overflow	Execution error	
	68	Illegal label jump or subprogram call	Execution error	
	69	Divided by 0 error	Execution error	When stack size, or stack elements are smaller than zero, or stack element number exceeds the limit of stack size
70	Definition error of stack operated	Execution error		
Instruction execution error (60 ~ 75)	71	Reserved		
	72	Undefined user subprogram or interrupt subprogram	Execution error	
	73	Using FROM/TO instruction to access module not existing	Execution error	
	74	I/O error when using FROM/TO instruction	Execution error	
	75	I/O error when using REF instruction	Execution error	
	76	Cannot set real time clock time using TWR	Execution error	
	77	Parameter 3 of PLSR instruction not inappropriate under constant scan	Execution error	
	78	BFM unit of accessed special module exceeds range	Execution error	
	79	ABS Data Read Timeout	Execution error	
	80	ABS Data Read and Check Error	Execution error	

Chapter 9 Instruction List

Type	Instruction	Function description
Basic instruction	LD	NO contact power-flow loading
	LDI	NC contact power-flow loading
	AND	NO contact power-flow and
	ANI	NC contact power-flow and
	OR	NO contact power-flow or
	ORI	NC contact power-flow or
	OUT	Power-flow output
	SET	Set
	RST	Reset
	ANB	Power-flow block and
	ORB	Power-flow block or
	INV	Power-flow block inverse
	NOP	No operation
	MPS	Output power-flow input stack
	MRD	Read output power-flow stack top value
	MPP	Output power-flow stack pop off
	MC	Main control
	MCR	Main control reset
	EU	Power flow rising edge detection
	ED	Power flow trailing edge detection
	TON	On-delay timing
	TOF	Off-delay timing
	TMON	Monostable timing
	TONR	On-delay remember timing
	CTU	16-bit counter counting up
	CTR	16-bit counter loop cycle counting
DCNT	32-bit counting	
Program control instruction	LBL	Jump label definition
	CJ	Conditional jump
	CALL	Calling a subprogram
	CSRET	Conditional return from user subprogram
	CFEND	Conditional end from user main program
	CIRET	Conditional return from user interrupt subprogram
	FOR	Cycle
	NEXT	Return from cycle
	WDT	User program watchdog reset
	STOP	User program stop
	EI	Enable interrupt
	DI	Disable interrupt
	SFC instruction	STL
SET Sxx		SFC state shift
OUT Sxx		SFC state jump
RST Sxx		SFC state reset
RET		SFC program end

Type	Instruction	Function description	
Data transmission instruction	MOV	Move word data transmission	
	DMOV	Move double word data transmission	
	RMOV	Move floating point number data transmission	
	BMOV	Move data block transmission	
	SWAP	Swap bytes	
	XCH	Swap bytes	
Dataflow instruction	DXCH	Exchange double word	
	FMOV	Fill data block	
	DFMOV	Fill data block double word	
	WSFR	Shift right word	
	WSFL	Shift left word	
	PUSH	Push	
	FIFO	First-in-first-out	
	LIFO	Last-in-first-output	
	ADD	Integer math	
	DADD	Add double integer	
Integer math instruction	SUB	Subtract integer	
	DSUB	Subtract double integer	
	INC	Increment integer	
	DINC	Increment double integer	
	DEC	Decrement integer	
	DDEC	Decrement double integer	
	MUL	Multiply integer	
	DMUL	Multiply double integer	
	DIV	Divide integer	
	DDIV	Divide double integer	
	VABS	Integer absolute value	
	DVABS	Double integer absolute value	
	NEG	Negative integer	
	DNEG	Negative double integer	
	SQT	Square root integer	
	DSQT	Square root double integer	
	SUM	Sum integer	
	DSUM	Sum double integer	
	Floating point number math instruction	RADD	Add floating point number
		RSUB	Subtract floating point number
RMUL		Multiply floating point number	
RDIV		Divide floating point number	
RVABS		Floating point number absolute value	
RNEG		Negative floating point number	
RSQT		Square root floating point number	
SIN		Floating point number SIN	
COS		Floating point number COS	
TAN		Floating point number TAN	
LN		Floating point number LN	
EXP		Floating point number EXP	
POWER		Floating point number exponentiation	
RSUM		Sum floating point number	

Type	Instruction	Function description
Word logic instruction	WAND	AND word
	DWAND	AND double word
	WOR	OR word
	DWOR	OR double word
	WXOR	Exclusive-OR word
	DWXOR	Exclusive-OR double word
	WINV	NOT word
	DWINV	NOT double word
Shift / rotate instruction	ROR	16-bit circular shift right
	DROR	32-bit circular shift right
	ROL	16-bit circular shift left
	DROL	32-bit circular shift left
	RCR	16-bit carry circular shift right
	DRCR	32-bit carry circular shift right
	RCL	16-bit carry circular shift left
	DRCL	32-bit carry circular shift left
	SHR	16-bit shift right word
	DSHR	32-bit shift right word
	SHL	16-bit shift left
	DSHL	32-bit shift left
	SFTL	Shift left byte
	SFTR	Shift right byte
Enhanced bit logic instruction	DECO	Decode
	ENCO	Encode
	BITS	Counting ON bit in word
	DBITS	Counting ON bit in double word
	ZRST	Batch bit reset
	ZSET	Set batch bit
High speed I/O instruction	HCNT	High-speed counter drive
	DHSCS	High-speed counting compare set
	DHSCR	High-speed counting compare reset
	DHSCI	High-speed counting compare interrupt trigger
	DHSZ	High-speed counting zone compare
	DHST	High-speed counting table compare
	DHSP	High-speed counting table compare pulse output
	SPD	Pulse detection
	PLSY	Count pulse output
	PLSR	Count pulse with acceleration/deceleration output
	PWM	PWM pulse output
	PLS	Pulse Output Instruction of Envelope
	Control calculation instruction	PID
RAMP		Ramp wave signal output
TRIANGLE		Triangle wave signal output
HACKLE		Hackle wave signal output
External equipment instruction	FROM	Read word form special module buffer register
	DFROM	Read double word form special module buffer register
	TO	Write word to special module buffer register
	DTO	Write double word to special module buffer register
	VRRD	Read analog potentiometer value
	REFF	Set input filtering constant
	REF	Instant refresh I/O
	EROMWR	EEPROM write

Type	Instruction	Function description
Positioning instruction	ABS	Read current value
	ZRN	Zero return
	PLSV	Variable speed pulse output
	DRVI	Relative position control
	DRVA	Absoloute position control
Real-time clock instruction	TRD	Read real-time clock
	TWR	Write real-time clock
	TADD	Add clock
	TSUB	Subtract clock
	HOURL	Timing list
Compare contact instruction	LD=	Compare integer LD=
	LDD=	Compare double integer LDD=
	LDR=	Compare floating point number LDR=
	LD>	Compare integer LD>
	LDD>	Compare double integer LDD>
	LDR>	Compare floating point number LDR>
	LD>=	Compare integer LD>=
	LDD>=	Compare double integer LDD>=
	LDR>=	Compare floating point number LDR>=
	LD<	Compare integer LD<
	LDD<	Compare double integer LDD<
	LDR<	Compare floating point number LDR<
	LD<=	Compare integer LD<=
	LDD<=	Compare double integer LDD<=
	LDR<=	Compare floating point number LDR<=
	LD<>	Compare integer LD<>
	LDD<>	Compare double integer LDD<>
	LDR<>	Compare floating point number LDR<>
	AND=	Compare integer AND=
	ANDD=	Compare double integer ANDD=
	ANDR=	Compare floating point number ANDR=
	AND>	Compare integer AND>
	ANDD>	Compare double integer ANDD>
	ANDR>	Compare floating point number ANDR>
	AND>=	Compare integer AND>=
	ANDD>=	Compare double integer ANDD>=
	ANDR>=	Compare floating point number ANDR>=
	AND<	Compare integer AND<
	ANDD<	Compare double integer ANDD<
	ANDR<	Compare floating point number ANDR<
	AND<=	Compare integer AND<=
	ANDD<=	Compare double integer ANDD<=
	ANDR<=	Compare floating point number ANDR<=
	AND<>	Compare integer AND<>
	ANDD<>	Compare double integer ANDD<>
	ANDR<>	Compare floating point number ANDR<>
	OR=	Compare integer OR=
	ORD=	Compare double integer ORD=
	ORR=	Compare floating point number ORR=
	OR>	Compare integer OR>
	ORD>	Compare double integer ORD>
	ORR>	Compare floating point number ORR>
	OR>=	Compare integer OR>=
	ORD>=	Compare double integer ORD>=
	ORR>=	Compare floating point number ORR>=
	OR<	Compare integer OR<
	ORD<	Compare double integer ORD <
ORR<	Compare floating point number ORR>	

Type	Instruction	Function description
Compare contact instruction	OR<=	Compare integer OR<=
	ORD<=	Compare double integer ORD<=
	ORR<=	Compare floating point number ORR<=
	OR<>	Compare integer OR<>
	ORD<>	Compare double integer ORD<>
	ORR<>	Compare floating point number ORR<>
Data Converting instruction	ITD	Integer to double integer
	DTI	Double integer to integer
	FLT	Integer to floating point number
	DFLT	Double integer to floating point number
	INT	Floating point number to integer
	DINT	Floating point number to double integer
	BCD	Word to 16-bit BCD
	DBCD	Couple word to 32-bit BCD
	BIN	16-bit BCD to word
	DBIN	32-bit BCD to double word
	GRY	Word to 16-bit gray code
	DGRY	Double word to 32-bit gray code
	GBIN	16-bit gray code to word
	DGBIN	32-bit gray code to double word
	SEG	Word to 7-segment encode
	ASC	ASCII Code conversion
ITA	Hexadecimal integer-ASCII conversion	
ATI	ASCII -hexadecimal integer conversion	
Word contactor instruction	BLD	Word bit contactor LD
	BLDI	Word bit contactor LDI
	BAND	Word bit contactor AND
	BANI	Word bit contactor ANI
	BOR	Word bit contactor OR
	BORI	Word bit contactor ORI
	BSET	Word bit coil set
	BRST	Word bit coil reset
	BOUT	Word bit coil output

Type	Instruction	Function description
Communication command	MODBUS	MODBUS master station communication
	XMT	Free-port sending (XMT)
	RCV	Free-port receiving (RCV)
	EVFWD	MDI forward rotation
	EVREV	MDI reverse rotation
	EVDFWD	MDI touch forward rotation
	EVDREV	MDI touch reverse rotation
	EVSTOP	Inverter stop
	EVFRQ	MDI set frequency
	EWRT	MDI write single register value
	EVRDST	MDI read status
Data check instruction	EVRD	MDI read single register value
	CCITT	CCITT check
	CRC16	CRC16 check
Date compare instruction	LRC	LRC check
	DCMP=	Compare date=
	DCMP>	Compare date>
	DCMP<	Compare date<
	DCMP>=	Compare date>=
	DCMP<=	Compare date<=
	DCMP<>	Compare date<>
Time compare instruction	TCMP=	Compare time=
	TCMP>	Compare time>
	TCMP<	Compare time<
	TCMP>=	Compare time>=
	TCMP<=	Compare time<=
	TCMP<>	Compare time<>

Chapter 10 Special Register

The special register includes the special intermediate relay and special data register.

10.1 Special Intermediate Relay

All special registers are initialized when system status changes from STOP to RUN. Those that have been set in system setting will be set to the preset value after that initialization. The features of the special intermediate relay are listed in Table 10-1 ~ Table 10-18. The reserved SD's and SM's are not listed in the table. By default, the reserved SM registers are read only (R).

Table 10-1 PLC status

Address	Name	Action and function	R/W
SM0	Monitoring run bit	Always high in the RUN state, and always low in the STOP state	R
SM1	Initial run pulse bit	User program from STOP to RUN, set high for an operation cycle, then set low	R
SM2	Power on flag bit	Set to high upon system power on, and to low after a operation cycle of user program	R
SM3	System error	When detecting system error upon power on or STOP-RUN, the bit resets; if there is not any system error, the bit is reset	R
SM4	Reserved		
SM5	AC power off detecting	The bit is set when AC power off is detected (detecting time 40ms). If the power is on after the delay of power off detecting time (set in SD05), the bit is reset	R
SM6	24Vdc power off	The bit is set when 24Vdc power off is detected (detecting time 50ms). If the 24Vdc power is on after 50ms, the bit is reset	R
SM7	Reserved		R
SM8	Constant scan mode	When the bit is set, the scan time is constant (configurable only through the system block)	R
SM9	Input point start up mode	When the bit is set, and the set X input point is ON, PLC can be STOP → RUN (configurable only through the system block)	R

Table 10-2 Clock bit

Address	Name	Act and function	R/W
SM10	10ms clock	Clock oscillation period: 10ms (turn over per half period. Half of the first user program period: 0)	R
SM11	100ms clock	Clock oscillation period: 100ms (turn over per half period. Half of the first user program period: 0)	R
SM12	1s clock	Clock oscillation period: 1s (turn over per half period. Half of the first user program period: 0)	R
SM13	1min clock	Clock oscillation period: 1min (turn over per half period. Half of the first user program period: 0)	R
SM14	1hour clock	Clock oscillation period: 1h (turn over per half period. Half of the first user program period: 0)	R
SM15	Scan period oscillation bit	This bit turns over once per scan period (the first period of the user program is 0)	R

Table 10-3 User program execution error

Address	Name	Act and function	R/W
SM20	Instruction execution error	The bit is set upon instruction execution error, and the error type code is written in SD20 at the same time. It is reset upon correct instruction execution	R
SM21	Instruction register number subscript overflow	The bit is set upon instruction execution error, and the error type code is written in SD20 at the same time. It is reset upon correct instruction execution	R
SM22	Instruction parameter illegal	The bit is set upon instruction execution error, and the error type code is written in SD20 at the same time. It is reset upon correct instruction execution	R

Table 10-4 Interrupt control

Address	Name	Act and function	R/W
SM40	X0 input rising/falling edge interrupt enable flag bit	Set as 1 to enable entering X0 rising edge (falling edge) interrupt	R/W
SM41	X1 input rising/falling edge interrupt enable flag bit	Set as 1 to enable entering X1 rising edge (falling edge) interrupt	R/W
SM42	X2 input rising/falling edge interrupt enable flag bit	Set as 1 to enable entering X2 rising edge (falling edge) interrupt	R/W

Address	Name	Act and function	R/W
SM43	X3 input rising/falling edge interrupt enable flag bit	Set as 1 to enable entering X3 rising edge (falling edge) interrupt	R/W
SM44	X4 input rising/falling edge interrupt enable flag bit	Set as 1 to enable entering X4 rising edge (falling edge) interrupt	R/W
SM45	X5 input rising/falling edge interrupt enable flag bit	Set as 1 to enable entering X5 rising edge (falling edge) interrupt	R/W
SM46	X6 input rising/falling edge interrupt enable flag bit	Set as 1 to enable entering X6 rising edge (falling edge) interrupt	R/W
SM47	X7 input rising/falling edge interrupt enable flag bit	Set as 1 to enable entering X7 rising edge (falling edge) interrupt	R/W
SM48	PORT0 character sending interrupt enable flag bit	Set as 1 to enable	R/W
SM49	PORT0 character receiving interrupt enable flag bit	Set as 1 to enable	R/W
SM50	PORT0 frame sending interrupt enable flag bit	Set as 1 to enable	R/W
SM51	PORT0 frame receiving interrupt enable flag bit	Set as 1 to enable	R/W
SM52	PORT1 character sending interrupt enable flag bit	Set as 1 to enable	R/W
SM53	PORT1 character receiving interrupt enable flag bit	Set as 1 to enable	R/W
SM54	PORT1 frame sending interrupt enable flag bit	Set as 1 to enable	R/W
SM55	PORT1 frame receiving interrupt enable flag bit	Set as 1 to enable	R/W
SM56	AC power failure interrupt	Set as 1 to enable	R/W
SM57	Reserved		
SM58	Reserved		
SM59	Reserved		
SM60	Reserved		
SM61	Reserved		
SM62	Reserved		
SM63	High speed output 0 finish interrupt enable flag bit	Set as 1 to enable the highspeed output counter interrupt 0	R/W
SM64	High speed output 1 finish interrupt enable flag bit	Set as 1 to enable the highspeed output counter interrupt 1	R/W
SM65	High speed counting interrupt enable flag bit	Set as 1 to enable the highspeed input counter interrupt	R/W
SM66	Timed interrupt 0 enable flag bit	Set as 1 to enable the timed interrupt 0	R/W
SM67	Timed interrupt 1 enable flag bit	Set as 1 to enable the timed interrupt 1	R/W
SM68	Timed interrupt 2 enable flag bit	Set as 1 to enable the timed interrupt 2	R/W

Table 10-5 High-speed output control

Address	Name	Act and function	R/W
SM80	Y000 pulse output stop intrusion	Y000 pulse will be disabled after this bit is set	R/W
SM81	Y001 pulse output stop intrusion	Y001 pulse will be disabled after this bit is set	R/W
SM82	Y000 pulse output monitor (busy /ready)	ON: busy. OFF: ready	R
SM83	Y001 pulse output monitoring (busy /ready)	ON: busy. OFF: ready	R
SM85	Reset function valid	Set to enable the CLR signal output of ZRN	R/W

Table 10-6 Pulse catch bit

Addresses	Name	Act and function	R/W
SM90	Input X000 pulse catch monitoring bit	1. When STOP→RUN, reset 2. When the port has HCNT high speed count drive instruction and SPD pulse density detecting instruction, the pulse catch of the port is invalid; and it is valid in other situations. See SPD and HCNT instructions for detailed information.	R/W
SM91	Input X001 pulse catch monitoring bit		R/W
SM92	Input X002 pulse catch monitoring bit		R/W
SM93	Input X003 pulse catch monitoring bit		R/W
SM94	Input X004 pulse catch monitoring bit		R/W
SM95	Input X005 pulse catch monitoring bit		R/W
SM96	Input X006 pulse catch monitoring bit		R/W
SM97	Input X007 pulse catch monitoring bit		R/W

Table 10-7 Free port (COM 0)

Address	Name	Act and function	R/W
SM110	Port 0 sending enable flag	The bit is set when using XMT instruction, and is reset after sending is finished. When the bit is reset, the current sending task of the Port 0 is paused; and it continues to send when the power-flow is on	R/W
SM111	Port 0 receiving enable flag	The bit is set when using RCV instruction, and is reset after receiving is finished. When the bit is reset, the current receiving task of the Port 0 is paused; and it continues to receive when the power-flow is on	R/W
SM112	Serial port 0 sending END flag	The bit is set when the sending is finished	R/W
SM113	Serial port 0 receiving END flag	The bit is set when the receiving is finished	R/W
SM114	Serial port 0 idle flag	The flag bit is set when the serial port does not have communication task	R

Table 10-8 Free port (COM 1)

Address	Name	Act and function	R/W
SM120	Port 1 sending enable flag	The bit is set when using XMT instruction, and is reset after sending is finished. When the bit is reset, the current sending task of the Port 1 is paused; and it continues to send when the power-flow conducts	R/W
SM121	Port 1 receiving enable flag	The bit is set when using RCV instruction, and is reset after receiving is finished. When the bit is reset, the current receiving task of the Port 1 is paused; and it continues to receive when the power-flow conducts	R/W
SM122	Port 1 sending finished flag	The bit is set when the sending is finished	R/W
SM123	Port 1 receiving finished flag	The bit is set when the receiving is finished	R/W
SM124	Serial port 1 idle flag	The flag bit is set when the serial port does not have communication task	R

Table 10-9 MODBUS communication

Address	Name	Act and function	R/W
SM130	Reserved		
SM131	Reserved		
SM132	Reserved		
SM133	Reserved		
SM134	Reserved		
SM135	PORT1 MODBUS communication finished	The bit is set when the communication is finished	R/W
SM136	PORT1 MODBUS communication faulty	The bit is set when the communication is faulty	R/W
SM137	Reserved		
SM138	Reserved		

Table 10-10 N:N NETWORK communication

Address	Name	Act and function	R/W
SM140	0 station communication error flag		R
SM141	1 station communication error flag		R
SM142	2 station communication error flag		R
SM143	3 station communication error flag		R
SM144	4 station communication error flag		R
SM145	5 station communication error flag		R
SM146	6 station communication error flag		R
SM147	7 station communication error flag		R
SM148	8 station communication error flag		R
SM149	9 station communication error flag		R
SM150	10 station communication error flag		R
SM151	11 station communication error flag		R
SM152	12 station communication error flag		R
SM153	13 station communication error flag		R
SM154	14 station communication error flag		R
SM155	15 station communication error flag		R
SM156	16 station communication error flag		R
SM157	17 station communication error flag		R
SM158	18 station communication error flag		R
SM159	19 station communication error flag		R

Address	Name	Act and function	R/W
SM160	20 station communication error flag		R
SM161	21 station communication error flag		R
SM162	22 station communication error flag		R
SM163	23 station communication error flag		R
SM164	24 station communication error flag		R
SM165	25 station communication error flag		R
SM166	26 station communication error flag		R
SM167	27 station communication error flag		R
SM168	28 station communication error flag		R
SM169	29 station communication error flag		R
SM170	30 station communication error flag		R
SM171	31 station communication error flag		R

Table 10-11 Enable flag of integrated analog signal

Address	Name	Act and function	R/W
SM172	Enable flag of AD channel 0	1: sampling of AD channel 0 enabled	R/W
SM173	Enable flag of AD channel 1	1: sampling of AD channel 1 enabled	R/W
SM174	Voltage/current enable flag of AD channel 0	1: current input. 0: voltage input	R/W
SM175	Voltage/current enable flag of AD channel 1	1: current input. 0: voltage input	R/W
SM176	Reserved		
SM177	Reserved		
SM178	Enable flag of DA channel 0	1: output of DA channel 0 enabled	R/W

Table 10-12 Arithmetic flag bit

Address	Name	Act and function	R/W
SM180	Zero flag bit	When the related operation result is zero, the bit is opened upon the execution of related instruction. Users can reset or set the bit manually	R/W
SM181	Carry/overflow flag bit	When the related operation generates a carry, the bit is opened upon the execution of related instruction. Users can reset or set the bit manually	R/W
SM182	Borrow	When the related operation generates a borrow, the bit is opened upon the execution of related instruction. Users can reset or set the bit manually.	R/W
SM185	Table compare flag	The bit is set when the whole table record is completed	R/W

Table 10-13 ASCII conversion instruction flag

Address	Name	Act and function	R/W
SM186	ASCII instruction storage mode flag	The most & LSB of each word stores one ASCII code respectively The LSB of each word stores one ASCII code	R/W

Table 10-14 System bus error flag

Address	Name	Act and function	R/W
SM190	Basic module bus error flag bit	1. Reset when the addressing is right upon power on 2. Reset when no error in the process of STOP→RUN 3. Reset when downloading new program 4. The bit can stop the system	R
SM191	General module bus error flag bit	1. The bit is set and the system raises an alarm when the general module bus operation error occurs 2. The flag is reset automatically when the system error is removed	R
SM192	Special module bus error flag bit	1. The bit is set and the system gives an alarm when the special module bus operation error occurs 2. The flag is reset automatically when the system error is removed.	R

Table 10-15 Realtime clock error flag

Address	Name	Act and function	R/W
SM193	Read/write real-time clock error	The bit is set when the real-time clock error occurs. The flag is reset automatically when the system error is removed	R

Table 10-16 EEPROM flag

Address	Name	Act and function	R/W
SM196	EEPROM write idle flag	The bit is set when there is no writing in the EEPROM	R

Table 10-17 Up/down counter counting direction

Address	Counter address	Function	R/W
SM200	C200	When SM2 __ is of high level, the corresponding C 2__ becomes a down counter When SM2 __ is of low level, the corresponding C 2__ becomes a up counter	R/W
SM201	C201		R/W
SM202	C202		R/W
SM203	C203		R/W
SM204	C204		R/W
SM205	C205		R/W
SM206	C206		R/W
SM207	C207		R/W
SM208	C208		R/W
SM209	C209		R/W
SM210	C210		R/W
SM211	C211		R/W
SM212	C212		R/W
SM213	C213		R/W
SM214	C214		R/W
SM215	C215		R/W
SM216	C216		R/W
SM217	C217		R/W
SM218	C218		R/W
SM219	C219		R/W
SM220	C220		R/W
SM221	C221		R/W
SM222	C222		R/W
SM223	C223		R/W
SM224	C224		R/W
SM225	C225		R/W
SM226	C226		R/W
SM227	C227		R/W
SM228	C228	R/W	
SM229	C229	R/W	
SM230	C230	R/W	
SM231	C231	R/W	
SM232	C232	R/W	
SM233	C233	R/W	
SM234	C234	R/W	
SM235	C235	R/W	

Table 10-18 High-speed counter counting direction and monitoring

Type	Address	Name	Register content	R/W
Single-phase single- input	SM236	C236	The high & low level of the SM2 __ corresponds to the counting down & up of the counter respectively	R/W
	SM237	C237		R/W
	SM238	C238		R/W
	SM239	C239		R/W
	SM240	C240		R/W
	SM241	C241		R/W
	SM242	C242		R/W
	SM243	C243		R/W
SM244	C244	R/W		

Type	Address	Name	Register content	R/W
Dual-phase single- input	SM245	C245	When the dual-phase single-input counter and dual-phase up/down counter C2 __ is in the down counting mode, the corresponding SM2 __ becomes high level; when in up counting mode, the corresponding SM2 __ becomes low level	R/W
	SM246	C246		R/W
	SM247	C247		R/W
	SM248	C248		R/W
	SM249	C249		R/W
Dual-phase up/down input	SM250	C250		R/W
	SM251	C251		R/W
	SM252	C252		R/W
	SM253	C253		R/W
	SM254	C254		R/W
	SM255	C255		R/W

10.2 Special Data Register

The features of special data registers are shown in Table 10-19 ~ Table 10-33. Note that all the special data registers except SD50 ~ SD55 will be initialized in the process of STOP→RUN. The reserved SD's and SM's are not listed in the table. The reserved SD's are by default read only (R).

Table 10-19 PLC status

Address	Name	Act and function	R/W	Range
SD00	PLC type	20 represents IVC2, and 10 represents IVC1	R	
SD01	Version No.	For example: 100 represents 1.00	R	
SD02	Capacity of user program	For example: 8 represents a 8k-word program	R	
SD03	System error code	System error code in storage	R	
SD04	Battery voltage value	Useless in an IVC1 basic module	R	
SD05	AC powre off detection delay time setting value	Regarded as 10ms for a setting smaller than 10ms, or 100ms for a setting bigger than 100ms (Configurable only through the system block)	R	10 ~ 100ms
SD07	Extension I/O module number		R	
SD08	Special module number		R	
SD09	Setting operation control input point, using decimal system (for example, X0 is displayed as 0; X10, 8; the maximum number is 15) (Configurable only through the system block).		R	0 ~ 15
SD10	Basic module I/O points	The most significant bit (MSB): input; The least significant bit (LSB): output	R	
SD11	Extension module I/O points	MSB: input; LSB: output	R	
SD12	Basic module analog I/O points	MSB: input; LSB: output	R	

Table 10-20 Operation error code FIFO area

Address	Name	Act and function	R/W	Range
SD20	Save run error code 0	Save the latest 5 run error type codes according to queue sequence; SD20 always saves the type codes of the latest error	R	
SD21	Save run error code 1		R	
SD22	Save run error code 2		R	
SD23	Save run error code 3		R	
SD24	Save run error code 4		R	

Table 10-21 FROM/TO error

Address	Name	R/W	Range
SD25	The special modules' numbering is wrong (starting from 0) when using FROM/TO instruction	R	Initial value: 255
SD26	The I/O chips' numbering is wrong (starting from 0) when refreshing I/O	R	Initial value: 255

Table 10-22 Scan time

Address	Name	Act and function	R/W	Range
SD30	Current scan value	Current scan time (unit: ms)	R	
SD31	Minimum scan time	Minimum value of scan time (unit: ms)	R	
SD32	Maximum scan time	Maximum value of scan time (unit: ms)	R	
SD33	Constant scan time setting	Initial value: 0ms, unit: 1ms. When the constant scan time is longer than the user monitoring overtime setting, user program overtime alarm will be raised. When a scan cycle of user program is longer than the constant scan time, the cycle constant scan mode is invalid automatically and no alarm will be raised. SD33 is regarded as 1000ms when it is set bigger than 1000ms (configurable only through the system block)	R	0 ~ 1000ms
SD34	User program overtime setting	Initial value: 100ms, adjustable through user program. The change will be effective in the next scan cycle. SD34 is regarded as 100 when it is set smaller than 100; or as 1000 when it is set bigger than 1000. (Configurable only through the system block)	R	100 ~ 1000ms

Note

1. There is a difference of 1ms among SD30, SD31 and SD32.
2. The user program overtime error may often occur when the difference between constant scan time SD33 and the user program overtime SD34 is not big enough. It is recommended to set SD34 5ms bigger than SD33.

Table 10-23 Input filtering time constant setting

Address	Name	Act and function	R/W	Range
SD35	Input filter regulation constant	Configurable only through the system block. Options: 0, 8, 16, 32, 64 ms	R	0 ~ 64

Table 10-24 High speed pulse output monitoring

Address	Name	R/W	Range
SD50	PLSR/PLSY instruction output Y0 pulse total number (MSB)	R/W	
SD51	PLSR/PLSY instruction output Y0 pulse total number (LSB)	R/W	
SD52	PLSR/PLSY instruction output Y1 pulse total number (MSB)	R/W	
SD53	PLSR/PLSY instruction output Y1 pulse total number (LSB)	R/W	
SD54	PLSR/PLSY instruction output Y1, Y0 pulse total number (MSB)	R/W	
SD55	PLSR/PLSY instruction output Y1, Y0 pulse total number (LSB)	R/W	
SD56	PLS outputs the segment that Y0 instruction is being executed	R	
SD57	PLS outputs the segment that Y1 instruction is being executed	R	

Note: SD50 ~ SD55 are reset upon system reset

Table 10-25 Timed interrupt cycle

Address	Name	Register content	R/W	Range
SD66	Timed interrupt 0 cycle setting	No interrupt when the setting is outside 1~32767	R/W	1 ~ 32767ms
SD67	Timed interrupt 1 cycle setting	No interrupt when the setting is outside 1~32767	R/W	1 ~ 32767ms
SD68	Timed interrupt 2 cycle setting	No interrupt when the setting is outside 1~32767	R/W	1 ~ 32767ms

Note: There is a time difference of 1ms when system processes user timed interrupt. To ensure the normal operation of timed interrupt, it is recommended to set the timed interrupt period >5ms

Table 10-26 Positioning instruction

Address	Data length	Default	Function	R/W
SD80	MSB	0	Used as the register for the present value of Y000 output positioning instruction	R/W
SD81	LSB			R/W
SD82	MSB	0	Used as the register for the present value of Y001 output positioning instruction	R/W
SD83	LSB			R/W
SD84		100	Base speed of executing instructions ZRN, DRVI, and DRVA	R/W
SD85	MSB	100000	Max. speed of executing intructions ZRN, DRVI, and DRVA	R/W
SD86	LSB			R/W

Address	Data length	Default	Function	R/W
SD87	16	1000	Acc. and Dec. time upon execution of instructions ZRN, DRVI, and DRVA	R/W
SD88	16	1000	Envelope ascend time (ms)	R/W
SD89	16	1000	Envelope descend time (ms)	R/W

Table 10-27 Real time clock

Address	Name	Register content	R/W	Range
SD100	Year	For real-time clock	R	2000 ~ 2099
SD101	Month	For real-time clock	R	1 ~ 12 months
SD102	Day	For real-time clock	R	1 ~ 31 days
SD103	Hour	For real-time clock	R	0 ~ 23 hours
SD104	Minute	For real-time clock	R	0 ~ 59 minutes
SD105	Second	For real-time clock	R	0 ~ 59 seconds
SD106	Week	For real-time clock	R	0 (Sunday) ~ 6 (Saturday)

Configurable only through TWR instruction or the host

Table 10-28 Free port receiving control and status (Port 0)

Address	Name	Register content	R/W	Range	
SD110	Free port 0 mode state word	SD110.0 ~ SD110.2 Free port baud rate	b2, b1, b0 000: 38,400 baud rate 001: 19,200 baud rate 010: 9,600 baud rate 011: 4,800 baud rate 100: 2,400 baud rate 101: 1,200 baud rate	R	
		SD110.3 Stop bit	0: 1 bit stop bit 1: 2 bit stop bit		
		SD110.4 parity check	0: even parity 1: odd parity		
		SD110.5 parity check enabling	0: no parity check 1: parity check		
		SD110.6 Character data bit	Every character data bit 0: 8-bit character 1: 7-bit character		
		SD110.7 free-port receiving start mode	1: start character specified 0: start character unspecified		
		SD110.8 free-port receiving end mode	1: end character specified 0: end character unspecified		
		SD110.9 Free-port word overtime enabling	1: word overtime enabled 0: word overtime disabled		
		SD110.10 Free-port frame overtime enabling	1: frame overtime enabled 0: frame overtime disabled		
		SD110.11	Reserved		
		SD110.12	0: word register valid at LSB 1: word register valid at both MSBs and LSBs		
		SD110.13 ~ SD110.15	Reserved		
SD111	Start character		R/W		
SD112	End character		R/W		
SD113	Work overtime setting	Default: 0ms (word overtime omitted)	R/W	1 ~ 32767ms	
SD114	Frame overtime setting	Default: 0ms (frame overtime omitted)	R/W	1 ~ 32767ms	
SD115	Receiving completion message code	Bit 0: set when receiving ends Bit 1: set when specified end character is received Bit 2: set when max. character number is received Bit 3: set upon word overtime Bit 4: set upon frame overtime Bit 5: set upon parity check error Bits 6 ~ 15: reserved	R		
SD116	Character currently received		R		

Address	Name	Register content	R/W	Range
SD117	Number of characters being received		R	
SD118	Character currently sent		R	

Table 10-29 Free port receiving control and status (Port 1)

Address	Name	Register content	R/W	Range	
SD120	Free port 1 mode state word	SD120.0 ~ SD120.2 Free-port baud rate	b2, b1, b0 000: 38,400 baud rate 001: 19,200 baud rate 010: 9,600 baud rate 011: 4,800 baud rate 100: 2,400 baud rate 101: 1,200 baud rate	R	
		SD120.3 Stop bit	0: 1 bit stop bit 1: 2 bit stop bit		
		SD120.4 parity check	0: even parity 1: odd parity		
		SD120.5 parity check enabling	0: enabled 1: disabled		
		SD120.6 data bit of every character	Data bit of every character 0: 8-bit character 1: 7-bit character		
		SD120.7 free-port receiving start-character mode	1: start-character specified 0: start-character unspecified		
		SD120.8 free-port receiving end-character mode	1: end-character specified 0: end-character unspecified		
		SD120.9 Free port word overtime enabling	1: word overtime enabled 0: word overtime disabled		
		SD120.10 Free port frame overtime enabling	1: frame overtime enabled 0: frame overtime disabled		
		SD120.11	Reserved		
		SD120.12	0: word register valid at LSB 1: word register valid at both the most and LSBs		
		SD120.13 ~ SD120.15	Reserved		
SD121	Start character		R/W		
SD122	End character		R/W		
SD123	Word overtime setting	Default: 0ms (word overtime omitted)	R/W	0 ~ 32767ms	
SD124	Frame overtime setting	Default: 0ms (frame overtime omitted)	R/W	0 ~ 32767ms	
SD125	Receiving completion message code	Bit 0: set when receiving ends Bit 1: set when specified end character is received Bit 2: set when max. character number is received Bit 3: set upon word overtime Bit 4: set upon frame overtime Bit 5: set upon parity check error Bits 6 ~ 15: reserved	R		
SD126	Character currently received		R		
SD127	Total number of characters currently received		R		
SD128	Characters currently sent		R		

Table 10-30 MODBUS setting

Address	Name	R/W	Range
SD130	Set the node ID of this PLC in the PLC network through PORT0	R	N:N NETWORK (0 ~ 31)
SD131	PORT0 max. overtime (between transmission and receiving) / N:N NETWORK extra delay	R	
SD132	PORT0 retry times	R	MODBUS (0 ~ 100), N:N NETWORK (default: 3)
SD133	N:N NETWORK network refreshing mode (PORT0)	R	1 ~ 13 (default: 3)
SD134	Reserved		
SD135	Set the node ID of this PLC in the PLC network through PORT1	R	MODBUS (1 ~ 31), N:N NETWORK (0 ~ 31)
SD136	PORT1 max. overtime (between transmission and receiving)/N:N NETWORK extra delay	R	
SD137	PORT1 retry times	R	MODBUS (0 ~ 100), N:N NETWORK (default: 3)
SD138	N:N NETWORK network refreshing mode (PORT1)	R	1 ~ 13 (default: 3)
SD139	MODBUS master error code (PORT1)	R	

Table 10-31 Setting and reading of integrated analog signal

Address	Name	R/W	Range
SD172	AD channel 0 average sample value	R	
SD173	AD channel 0 sampling times	R/W	0 ~ 1000
SD174	AD channel 1 average sample value	R	
SD175	AD channel 1 sampling times	R/W	0 ~ 1000
SD178	DA channel 0 output value	R/W	

Table 10-32 Usage of instructions DHSP and DHST

Address	Name	R/W	Range
SD180	MSB of DHSP table comparison output data	R/W	
SD181	LSB of DHSP table comparison output data	R/W	
SD182	MSB of DHST or DHSP table comparison data	R/W	
SD183	LSB of DHST or DHSP table comparison data	R/W	
SD184	Record No. of the table being executed	R/W	

Table 10-33 Error occurrence flag

Address	Name	Act and function	R/W	Range
SD191	Module No. of common module bus error	Module number when common module bus error occurs	R	
SD192	Module No. of special module bus error	Module number when special module bus error occurs	R	